

Product Safety Information



Plain, Hand Chain (Geared), and Powered Non-Manrider Trolleys



Save These Instructions



Form MHD56291
Edition 1
December 2004
71446611

© 2004 Ingersoll-Rand Company

Only allow **Ingersoll-Rand** Certified Service Technicians to perform maintenance on these trolleys. For additional information contact **Ingersoll-Rand** or nearest Distributor.

The use of other than genuine **Ingersoll-Rand** replacement parts may result in safety hazards, decreased performance and increased maintenance and may invalidate all warranties.

The original language of this manual is English.

Manuals can be downloaded from www.airwinch.com.

Refer all communications to the nearest **Ingersoll-Rand** Office or Distributor.

SAFETY INFORMATION

WARNING

- Failure to follow these warnings may result in death or severe injury.

Additional information available on page 4.

■ General

- **Always install, operate, inspect and maintain this product in accordance with all applicable standards and regulations (local, state, country, federal, etc.).**
- **Read the latest edition of ASME/ANSI B30.16 "Overhead Hoists" and for electrically powered trolleys the National Electric Code (ANSI/NFPA 70). Comply with other federal, state and local rules.**

■ Trolley Installation

- **Do not remove or obscure any warning label or tag.**
 - Ensure warning label(s) or tag(s) are visible to the personnel in the area.
 - If warning label(s) or tag(s) are damaged, illegible or become lost, contact your nearest distributor or the factory for free replacement.

■ Before Operating Trolley

- **Do not operate this trolley before reading Product Information Manuals.**
 - Read all documentation supplied with the trolley.
 - Contact factory if in doubt about installation, operation, inspection and maintenance instructions.
 - Do not discard manuals. Keep manuals readily available for all personnel.

■ When Operating Trolley

- **Handling people with this equipment. Can cause severe injury or death.**
 - Do not use for lifting, lowering or transporting people.
- **Do not use trolley mounted hoists to lift people or loads over people.**
 - Be aware of the location of all other personnel in the job area.
 - Cordon off area and install warning signage around job areas and along intended load paths.
 - Never allow anyone to stand under or on a suspended load.
 - Make sure everyone is clear of the intended load path and there are no objects in the way of the load.
- **Do not use trolley to support more than rated load.**
 - Refer to "SPECIFICATIONS" section in trolley Product Information Manual for maximum trolley load rating.
 - Check trolley data (name) plate for maximum trolley load rating.
 - Exceeding the maximum rated trolley load can cause trolley or rigging failure allowing the load to drop.
 - Operator must be aware of weight of load being moved.
 - Always rig loads properly and carefully.
- **Do not operate unless load is centered under trolley.**
 - Check trolley is directly above load. Do not side pull or "yard" a load. Refer to Dwg. MHP2649 on page 8, **A**. 10 Degree Maximum angle in any direction; **B**. Correct.
 - Check load is securely inserted in the saddle of the hook, and that hook latch is engaged.
 - Pay attention to the load at all times when operating the trolley.

■ Additional Safety Procedures

- **Inspect trolley and rigging prior to every shift.**
 - These inspections are to identify equipment problems that must be repaired prior to trolley use.
 - Perform all steps in "Frequent Inspection" procedure described in "Product Information Manual" supplied with the trolley.
 - Additionally perform "Periodic Inspection" procedure described in "Product Information Manual" at recommended frequency based on use conditions.
- **Ensure all trolley components and attachments are functioning and properly adjusted.**
 - Move trolley slowly in each direction with no load and check operation.
- **Ensure trolley supporting structure is secure and in good condition.**
 - Supporting structure - Check for distortion, wear, rigidity and continued ability to support trolley and rated load. Ensure hoist is securely mounted to trolley.

- **Ensure powered trolley supply cables and hoses are in good condition and connections are tight.**
 - Failure of electric cables or their disconnection while power is supplied can result in electrocution.
 - Failure of air or hydraulic hoses or their disconnection while pressurized can result in hazardous situations including the whipping of hoses.
 - Keep clear of whipping hoses. Shut off the compressed air or hydraulic pressure before approaching the whipping hose.
- **Do not operate if malfunctioning or damage is found.**
 - Notify supervisory or maintenance personnel of any malfunction or damage.
 - Trained and authorized personnel must determine if repairs are required prior to operating trolley.
- **Use caution when operating in extremely cold temperatures.**
 - Extremely cold temperatures can affect the performance of some materials. Operate trolley with no load to lubricate parts prior to applying a load.
 - Ensure lubricants or hydraulic oil is suitable for operating temperatures.
 - Optional low temperature hoist/trolley are available. Refer to model number on the date (name) plate and hoist/trolley model code for approved operating temperature ranges.
- **Be aware of load position at all times to avoid moving load into hazardous situations.**
 - Operators must maintain visual contact with the load at all times.
 - Monitor surrounding conditions to prevent load from contacting hazardous obstructions.
 - Use spotters or signal-person to assist with positioning a load in confined or limited visibility areas.
 - Continually monitor load movement through all phases of operation.
- **Immediately stop operation if powered trolley does not respond to control.**
 - Check direction indicators on control match trolley direction.
 - Ensure all controls function smoothly and do not stick or bind when operated.
 - Keep controls dry and clean to avoid hand slippage resulting in loss of trolley control.
 - Test control functions prior to applying load to trolley.
 - Do not operate powered trolleys with damaged controls.
- **Always shut off air or power supply before servicing or leaving trolley unattended.**
 - Turn off, lock out power supply and activate control(s) several times to completely de-energize system.

■ Trolleys used in Potentially Explosive Atmospheres (ATEX)

- **Non-compliance with any of these "Special Conditions" could result in ignition of potentially explosive atmospheres.**
- **Refer to Ingersoll-Rand's specification supplied with the pneumatic hoist or trolley for proper filtering and lubrication in air supply line.**
- **Proper lubrication and maintenance are required to prevent premature component failures.**
- **Follow the recommendations in the lubrication and maintenance sections of the manual supplied with the hoist or trolley.**
- **Air pressure above 6.2 bar (620 kPa / 90 psig) at the trolley motor inlet may result in a source of ignition caused by premature failure of bearings or other components due to excessive speed, output torque or force.**
- **Do not operate the hoist or trolley with the air pressure at the inlet below 5.5 bar (550 kPa / 80 psig). Low air pressure to the hoist or trolley may cause the brake to partially engage during operation resulting in elevated temperatures.**
- **The entire hoist system, from the trolley or load hook to the bottom hook, the control pendant and the payload shall be earth grounded at all times to prevent ignition hazards from electrostatic discharge. A resistance to earth of less than 10000 Ohms is required. Do not disconnect or insulate any grounding or strain relief cables. When using a non-conductive sling or harness or a non-conductive link or barrier an independent ground must be applied.**
- **Never use a pneumatic hoist or trolley when there is any possibility that a gas in Group C (acetylene, carbon disulfide, and hydrogen, as defined in EN 50014), hydrogen sulfide, ethylene oxide, light metal dusts or dusts sensitive to impact may be present. These atmospheres cause a high probability of explosion.**
- **Do not allow hard contact of the bottom block, hook, load chain or pendant control against other objects. The impact of any hoist or trolley component beyond normal use may cause an ignition hazard from sparks.**

- The maximum expected surface temperature of the hoist or trolley is 135° C measured during brake malfunction. Inspect the hoist or trolley for air leaks and proper brake engagement, prior to operation.
- Check for abnormally elevated temperatures during operation that may be an indication of overload or potential failure of bearings, brake or other mechanical components.
- If elevated temperatures or elevated vibration levels are detected, shut the hoist and/or trolley off and discontinue its use until it can be inspected and/or repaired.
- Do not use a pneumatic hoist or trolley that exhibits rust or rust films that may come in contact with aluminum, magnesium or their corresponding alloys.
- Do not perform maintenance or repairs in an area where explosive atmospheres are present.
- Do not clean or lubricate a pneumatic hoist or trolley with flammable or volatile liquids such as kerosene, diesel or jet fuel. A potentially explosive atmosphere may be created.
- Hoists and trolleys with ATEX certification are intended for general industrial material handling use in conformance to their labeled designation and these special conditions. Special assessments, for other specific applications requiring increased protection, should be requested by written inquiry to Ingersoll-Rand.

NOTICE

- To safely use this product and conform with the provisions of the Machinery Directive 98/37/EC, all instructions given in the accompanying literature, in addition to all conditions, notices and warnings given herein, must be followed.

Warning Symbol Identification



A Safety Alert Warning



B Read Manuals Before Operating Product



C Pinching, Crushing Hazard



D Wear Eye Protection



E Wear Hearing Protection



F Do Not Lift People

(Dwg. MHP2585)

A. Safety Alert Warning; B. Read Manuals Before Operating Product; C. Pinching, Crushing Hazard; D. Wear Eye Protection; E. Wear Hearing Protection; F. Do Not Lift People.

INTRODUCTION

Ingersoll-Rand provides this manual to inform installers, operators, maintenance personnel, supervisors and management of safe practices that must be followed. It is important for the trolley operator to be instructed in the correct operation of trolleys and the severe consequences that may result from careless use.

This document supports all Ingersoll-Rand trolleys and therefore may contain information that is not applicable to your unit.

It is not intended that the recommendations in this manual take precedence over existing plant safety rules and regulations or OSHA regulations. In the event that some conflict exists between a rule set forth in this publication and a similar rule already set by an individual company, the more stringent of the two should take precedence. A thorough study of the information in this manual should provide a better understanding of safe operating procedures and afford a greater margin of safety for people and equipment.

WARNING

- Failure to read and comply with any of the limitations noted in this manual and the Ingersoll-Rand Operation Manuals can result in death or serious injury.

When following specific rules always:

“USE COMMON SENSE”

Even if you feel you are familiar with this or similar equipment, you should read this manual and appropriate trolley Operation Manuals before operating the trolley.

NOTICE

- It is a responsibility of the owner/user to install, operate, inspect and maintain trolley in accordance with all applicable Standards and Regulations. If the trolley is installed as part of a lifting system, it is also the responsibility of the owner/user to comply with the applicable standards that address other types of equipment used.

Only those Authorized and Qualified Personnel who have read and demonstrated comprehension of this manual and any other supporting documentation, and that are knowledgeable in the proper operation and use of the trolley should be permitted to operate the trolley.

Alert Signals

Throughout this manual there are steps and procedures which, if not followed, may result in a hazard. The following signal words are used to identify the level of potential hazard.

| | | |
|--|----------------|---|
| | DANGER | Indicates an imminently hazardous situation which, if not avoided, will result in death or serious injury. |
| | WARNING | Indicates a potentially hazardous situation which, if not avoided, could result in death or serious injury. |
| | CAUTION | Indicates a potentially hazardous situation which, if not avoided, may result in minor or moderate injury or property damage. |
| | NOTICE | Indicates information or a company policy that relates directly or indirectly to the safety of personnel or protection of property. |

The words **shall** and **should** are used throughout this manual in accordance with definitions in the ASME B30 standards as follows:

Shall - this word indicates that a rule is mandatory and must be followed.

Should - this word indicates that a rule is a recommendation, the advisability of which depends on the fact in each situation.

Also used in this manual and other manuals are the following words with definitions:

Owners/users - these words also refer to trolley operators.
Signalperson - person who observes load and relays directions to trolley operator.
Operation Manuals - documentation that is provided with the trolley that contains installation, parts information, maintenance, lubrication and related service instructions.

Pneumatic Trolleys Intended for use in Potentially Explosive Atmospheres (ATEX)

The EC Declaration of Conformity in the Product Information Manual states that these Pneumatic Trolley models are in compliance with European Community Directive 94/9/EC for equipment intended for use in potentially explosive atmospheres, commonly referred to as the ATEX Directive.

Trolley Models: TRU030()-E, TRU060()-E, TRU120()-E, TRU180()-E, TRU250()-E.

Standard Pneumatic Trolley models conform to and are marked for use as defined by ATEX designation:

II 3 GD c IIB 135°C X

Pneumatic Trolley models with the addition of the Ingersoll-Rand “ATEX” package of spark protection conform to and are marked for use as defined by ATEX designation:

II 2 GD c IIB 135°C X

These ATEX designations define the applications, the type and duration of the potentially explosive atmospheres, the type of protection, and the maximum surface temperature.

Trolleys and Hoists intended to be used in underground parts of mines as well as those parts of surface installations of such mines endangered by firedamp and/or combustible dust are marked for use as defined by ATEX designation:



The X indicates that additional special conditions are required for safe application, operation and/or maintenance of these tools when used in potentially explosive atmospheres.

These ATEX designations define the applications, type and duration of the potentially explosive atmospheres, type of protection, and the maximum surface temperature.



This symbol indicates certification for use in an explosive atmosphere and is followed by other symbols indicating the details of that certified use.

- II-** Indicates Equipment Group II - Non-Mine Use.
- 2-** Indicates Equipment Category 2 - Equipment Category 2 is intended for use in areas in which explosive atmospheres caused by gases, vapors, mists or air/dust mixtures are only occasionally likely to occur. Protection is ensured during normal use and in the event of frequently occurring disturbances or equipment faults.
- G-** Indicates evaluation for explosive atmospheres caused by gases, vapors or mists.
- D-** Indicates evaluation for explosive atmospheres caused by dust.
- c-** Indicates type of explosion protection per standard EN 13463-5 in which constructional measures are applied so as to provide safety against the possibility of ignition.
- IIB-** Indicates certification for use in Group B which covers gases with an MIC ratio of 0.45 to 0.8 and MESG value of 0.55 to 0.9 mm. If certified for Group B it would be safe in Group A, which covers gases with MIC ratio above 0.8 and MESG above 0.9 mm.

Tmax- Indicates the maximum surface temperature in degrees Centigrade.

X- Indicates that there are special conditions for safe application, installation, operation and maintenance which must be followed for the certification to apply.

■ Training Programs

It is a responsibility of the trolley owner/user to make personnel aware of all federal, state and local rules, codes and company safety rules, regulations and instructions and to establish programs to:

1. Train and designate trolley/hoist operators.
2. Train and designate trolley/hoist inspection and maintenance personnel.
3. Ensure safety procedures are followed.
4. Ensure all accidents or safety violations are properly reported, and appropriate corrective action is taken prior to further use.
5. Ensure that all trolley warning tags, labels and the Operation Manuals supplied with the trolley are read.

Applications in the USA

Training programs should include reading information contained in the latest edition of: ASME B30.16 - Safety Standard for Overhead Hoists (underhung). American Society of Mechanical Engineers, Three Park Avenue, New York, NY 10016. Also the, Hoist Inspection and Hoist Maintenance Personnel Manual published by the Hoist Manufacturers Institute, 8720 Red Oak Blvd., Suite 201, Charlotte, NC 28217-3992.

It is recommended that applicable US National Safety Council (NSC) and US Occupational Safety and Health Act (OSHA) standards be reviewed along with other recognized safety sources to provide safe hoist installation and operation.

Training programs should also include requirements in accordance with the latest edition of: ASME B30.9 - Safety Standards for Slings.

Applications outside the USA

Follow all country or regional specific rules, regulations and standards that apply to operator/user training.

WARNING LABELS AND TAGS

READ and OBEY all Danger, Warning, Caution, and Operating Instructions on the trolley and in all **Ingersoll-Rand** Manuals.

Check that all labels, tags and data (name) plates are in place and legible. Failure to comply with safety precautions described in the manuals supplied with the trolley, this manual or any of the labels and tags attached to the trolley is a safety violation that may result in death, serious injury, or property damage.

Each trolley is shipped from the factory with the warning label shown. If the label is not attached to your trolley, contact your nearest distributor or the factory for free replacement and attach it. Part number for the label used on the trolley is 71289326. Label is shown smaller than actual size.

Warning label is located on trolley side plate.



(Dwg. 71289326)

A. Handling people with this equipment. Can cause severe injury or death. Do not use for lifting, lowering or transporting people.

TROLLEY GENERAL INFORMATION

Ingersoll-Rand trolleys can be plain (non-powered), hand chain (geared) or powered (pneumatically, hydraulically or electrically). Hoists can be hook-mounted to the suspension shaft of the trolley, or rigidly mounted to a trolley hanger bracket.

■ Plain (Non-Powered) Trolley

These trolleys can freely move along the beam. Movement is dependant on suspended load and manual positioning by the operator.

■ Hand Chain (Geared) Trolley

These trolleys are moved by pulling down on one of the hand chain falls. The hand chain wheel is connected to a shaft that drives the trolley wheels.

■ Powered Trolley

These trolleys are equipped with a motor which in turn acts as the drive to the trolley wheels.

■ With Brake

Disc brakes are internal and connected to the drive train. They are automatically engaged, locking the drive train to the trolley frame, thereby stopping wheel movement when the control is released or placed in the neutral position.

INSTALLATION

Inspect shipping package for any signs of shipping damage. Remove shipping material carefully and inspect trolley for any damage. Any item that appears damaged no matter how slight shall be inspected and a determination made as to its suitability for use prior to trolley being placed into service.

Ensure that Warning and Operation labels and tags are not removed or covered during or after the installation process. Contact the factory for free replacement labels or tags if they become damaged or unreadable.

Ensure that data (name) plate is attached and readable. Refer to the Product Information Manuals for additional information. Replacement data (name) plates are available when complete trolley serial number is provided.

If trolleys are repainted, ensure labels and tags are protected and the protection is removed after painting.

Trolleys are supplied fully lubricated from the factory. Refer to Product Information Manual for trolley lubrication information.

CAUTION

• **Owners and users are advised to examine specific, local or other regulations, including American Society of Mechanical Engineers and/or OSHA Regulations which may apply to a particular type of use of this product before installing or putting trolley to use.**

It is the owner's and user's responsibility to determine the suitability of a product for any particular use. Review all applicable industry, trade association, federal and state regulations.

■ Site Survey

Inspect site where trolley will be mounted. Ensure that overhead suspension system can support the trolley. Refer to trolley Product Information Manuals for specific information on mounting requirements, attaching hardware and power supply. Survey site to ensure operator ability to reach hand chain or controls comfortably and observe loads during operation.

WARNING

• **Supporting structures and load-attaching devices used in conjunction with this trolley must meet or exceed the design safety factor to handle the rated load, plus the weight of the hoist and attached equipment. This is the customer's responsibility. If in doubt, consult a registered structural engineer.**

When installing a trolley ensure that installation personnel are trained and factory certified to perform the tasks. The use of licensed electricians or registered structural engineers might be required. Use of trained, certified personnel will ensure safe installation and that all items used in the installation will meet federal, state and local code requirements.

■ Moving the Trolley

WARNING

• **Do not lift trolley or attachments over people when moving or mounting trolley.**

Once the trolley is ready to move to the mounting site, weight of complete trolley must be determined. This will ensure that lifting equipment with enough capacity is used. The basic weight of the trolley is found in the trolley Product Information Manuals.

CAUTION

• **The addition of items to the trolley can affect the CENTER of GRAVITY. On the initial lift ensure trolley does not "roll, tilt or shift".**

To rig a trolley for moving, use nylon slings or hooks of the correct capacity in the lifting eyes when provided. Rig the trolley in a manner to prevent any "rolling or shifting" during movement. Ensure that lifting equipment has clear access and can easily reach the mounting site.

With trolley rigged to move and the correct lifting equipment attached, on the initial lift, only lift trolley a couple of inches (50 - 75 mm) and determine stability of rigging before continuing. If trolley is stable, continue with installation.

■ Mounting

Make certain your trolley is properly installed. A little extra time and effort in doing so can contribute a lot toward preventing accidents or injuries and will help achieve the best service possible.

Always make certain the supporting member from which the trolley is suspended is strong enough to support the weight of the trolley plus the weight of the maximum rated load plus a generous factor of at least 500% of the combined weights.

When installing a trolley on a beam, measure the beam flange width and temporarily install the trolley to determine the exact distribution and arrangement of the spacers. Refer to Trolley Product Information Manual for correct distance between the trolley wheel flanges and beam. Typically, spacers must be evenly distributed to keep the hoist centered under the beam. For additional information refer to the trolley manufacturer's literature. Ensure rail stops are installed.

■ Hook Mounted Hoist

After final trolley installation place hook over suspension shaft. Make sure hook latch is engaged.

If the hoist is suspended by a top hook, the suspension shaft should rest completely within the saddle of the hook and be centered directly above the hook shank. Do not use a trolley that tilts the hoist.

■ Rigid/Lug Mounted Hoist

Mount hoist to trolley and temporarily install on beam to determine exact distribution of spacers.

Ensure trolley bolts and/or nuts are torqued in accordance with manufacturer's specifications. When installing trolley on the beam, make certain the side plates are parallel and vertical.

After installation, operate trolley over entire length of beam with a capacity load suspended 4 to 6 inches (10 to 15 cms) off the floor.

CAUTION

• **To avoid an unbalanced load which may damage the trolley, the hoist must be centered under the trolley.**

NOTICE

• **Trolley wheels ride on the top of the lower flange of the beam.**

■ Ergonomics

On powered trolleys the operators' position at the controls should allow the operator to maintain a comfortable, well-balanced posture. The position should also allow easy access to all controls without reaching. In this position, the operator should be able to view the load during entire cycle of movement. This position should provide the maximum protection to operator.

The operators' position should also be free of obstructions both overhead and on the sides. The operators area must be well ventilated, kept oil free and clear of unnecessary equipment/tools etc. and be provided with a non-skid surface.

■ Power Supply (Powered Trolleys)

For all powered trolleys there is a recommended power supply input for the best performance, refer to the Product Information Manuals. A power supply of less than recommended will result in reduced trolley performance and may cause some items such as brakes or limit switches to function incorrectly.

Exceeding the power supply can cause trolley to exceed rated performance. Brakes, overload sensors, limit switches/valves may not function correctly.

WARNING

• **Ensure that all power supply connections are tight.**
• **Check electrical grounding (earth) is complete.**

Comply with any other safety precautions to ensure a good, safe, power source connection at the trolley.

Air and hydraulic powered trolleys require filtration before the control valve. Refer to Product Information Manuals for specific filtration level, type and location. Without filtration, contaminants can enter the system and cause components to malfunction.

Electric trolleys can also be affected by contamination. Keep motor and controls clean.

■ Exhaust (Powered Trolleys)

On air powered trolleys, careful consideration must be given to the exhaust. Make sure trolleys are positioned in a well ventilated area.

1. **Noise.** Use of a muffler is recommended to reduce noise level.
2. **Misting.** Clean and remove any build-up of oily residue in area.

- Natural/Sour Gas.** For air powered trolleys that use natural/sour gas as the power source, pipe away exhaust from trolleys. Exhaust system shall provide safe removal or recirculation of gas and meet all applicable federal, state, and local safety rules, codes and regulations.

■ Electrical Disconnect (Powered Trolleys)

Refer to the latest edition of the National Electrical Code (NFPA 70), Article 610-31.

Trolley Conductor Disconnecting Means

A disconnecting means that has a continuous ampere rating not less than that computed in Sections 610-14(e) and (f) of NFPA 70 shall be provided between the trolley contact conductors and the power supply. Such disconnecting means shall consist of a motor-circuit switch, circuit breaker, or molded case switch. This disconnecting means shall be as follows:

1. Readily accessible and operable from the ground or floor level.
2. Arranged to be locked in the open position.
3. Open all ungrounded conductors simultaneously.
4. Placed within view of the trolley contact conductors.

■ Shut-off Valve (Powered Trolleys)

On all air trolley installations an emergency shut-off valve/switch should be installed within easy range of the operator to provide a positive way of stopping trolley operation in the event of an emergency.

The valve should be positioned so that activation can occur quickly, and any person in the area of the trolley can also activate the valve. Train people to its location and use.

Refer to typical air powered trolley installation Dwg. MHP2459 on page 8.

A. Air Flow; B. Open; C. Closed; D. Ball Valve; E. Fitting Nipple.

■ Pendant (Powered Trolleys)

Check that all connections are tight and that lines are not twisted or crimped. Do not exceed maximum pendant length recommendations.



- To avoid damaging the pendant lines, make sure the strain relief cable, not the pendant lines, are supporting the weight of the pendant.

■ Trolley Controls

The location of controls and features varies between trolleys and is dependent on application requirements. Be familiar with location of controls and features.

Users and operators should not assume that all trolleys operate the same. Although there are many similarities, every trolley should be reviewed for different characteristics. Each trolley has specific characteristics that the operator must understand and be familiar with.



- It is the responsibility of the owner/user to require that all personnel that will install, inspect, test, maintain, and operate the trolley read the contents of this manual and the Operation Manuals furnished by Ingersoll-Rand and become thoroughly familiar with the location and operation of the controls and features.

The direction of travel and speed is managed by the control. Controls shall be clearly marked for direction of travel. Trolley control selection is dependent on power source, location to trolley and degree of control required.

For air trolleys, pilot pendant controls are normally used which are connected directly to the trolley motor. Pendants use levers or buttons to control travel. The degree of lever or button movement controls trolley speed.

Pendant controls send a signal back to a valve or control panel mounted to the trolley.

Trolley controls are available with an emergency stop button which when activated will cut power to the trolley.

TROLLEY OPERATORS DUTIES AND RESPONSIBILITIES

When operating a trolley, operators should always use personal protective equipment appropriate to the operation. As a minimum this should include safety glasses, hearing protection, gloves, safety shoes and hard hat. Other safety items as required by individual companies should also be used. The use of non-slip footwear is recommended if trolley is located in an area that may be muddy, wet or have slippery surfaces.



(Dwg. MHP2452)



(Dwg. MHP2455)



(Dwg. MHP2594)



(Dwg. MHP2596)



(Dwg. MHP2595)

■ Inspections

Daily visual inspections should be performed by the trolley operator at the start of each shift, or at the time the trolley is first used during each shift. Never use a trolley that inspection indicates is worn or damaged. Refer to "TROLLEY INSPECTION" section of the Product Information Manual provided with the trolley. The trolley operator shall not perform periodic inspections, or maintenance on a trolley unless the operator has been trained and factory certified to perform such inspections or maintenance, and is designated by the trolley owner to perform such inspections or maintenance.

■ Trolley Operators Responsibilities

The trolley operator must be carefully instructed in his or her duties and must understand the operation of the trolley, including a study of the manufacturer's

literature. The operator must thoroughly understand proper methods of rigging and attaching loads and should have a good attitude regarding safety. It is the operator's responsibility to refuse to operate the trolley under unsafe conditions.

Participate in any trolley and hoist training programs and be familiar with topics outlined in "Training Programs" on page 4.

It is the responsibility of the operator to exercise caution, use common sense and be familiar with operating procedures and duties.

Operators who are fatigued or have exceeded their normal shift period shall check all related regulations regarding approved work periods prior to operating trolley. Refer to "Training Programs" on page 4.

Trolley Operators Shall:

1. Physically competent and have no health condition which might affect their ability to act.
2. Be trained on trolley control and load movement direction before operating the trolley.
3. Watch for potential trolley malfunctions that may require adjustment or repair.
4. Check brake operation on powered trolleys with brake option.
5. When a "DO NOT OPERATE" sign is placed on the trolley, or controls, do not operate the trolley until the sign has been removed by designated personnel.
6. Operate the trolley with smooth control movements. Do not jerk the load.
7. Immediately stop operation if functions do not respond to controls.
8. NOT swing a load suspended from a trolley.
9. Never use a trolley to suspend a load for an extended period of time.
10. Be aware of shut-off valve or electrical disconnect location and proper operation.
11. Confirm that trolley inspections and lubrication checks have been completed.



- If a problem is detected, immediately STOP operation and notify supervisor. DO NOT continue operation until problem is corrected.

Trolley Operators Should:

1. Have normal depth perception, field of vision, hearing, reaction time, manual dexterity, and coordination for the work being performed.
2. NOT be subject to seizures, loss of physical control, physical defects, or emotional instability that could result in actions of the operator being a hazard to the operator or others.
3. NOT operate a trolley when under the influence of alcohol or drugs.
4. NOT operate a trolley when under the influence of medication that could result in actions of the operator being a hazard to the operator or others.

The operator must know the trolley capacity during all operations. It is the operators' responsibility to ensure that the load does not exceed the trolley rating. On **Ingersoll-Rand** data (name) plates the capacities of the trolley to which it is attached are listed. The data (name) plate information used in conjunction with the Product Information Manuals will give the operator the specific capacities of the trolley.

Items to consider as part of the load:

- All rigging items.
- Shock loads that could cause the load to exceed trolley rated capacity.
- Hoist or suspended equipment.

TROLLEY OPERATION

■ General Operating Instructions

The following operating instructions have been adapted in part from American National (Safety) Standard ASME B30.16 (Overhead Hoists) and are intended to avoid unsafe operating practices which might lead to injury or property damage. Refer to specific sections in the Product Information Manuals for additional safety information.

The four most important aspects of trolley operation are:

1. Follow all safety instructions when operating trolley.
2. Allow only people trained in safety and operation of this trolley to operate this equipment. Refer to "Training Program" on page 4.
3. Subject each trolley to a regular inspection and maintenance program.
4. Be aware of trolley capacity and weight of load at all times. Ensure load does not exceed trolley or rigging ratings.

■ Important Trolley Operating Procedures

Operators must maintain visual contact with the load at all times.

During all trolley operations, operator must be aware of load and its path. Load must have a free unobstructed path from pick up to set down. This awareness is to ensure that load does not contact any hazards. Some of the hazards to watch for and avoid are:

- power lines, telephone lines and electrical cables.
- guide wires, other load lines, strung hoses.
- personnel in the path or under the load as it is moved. Personnel shall NEVER be under or in the path of a moving load.
- lifting loads in wind gusts or high winds.
- bumping an obstacle such as buildings, support member, another load etc.

At the completion of trolley operation or when in a non-operational mode the following actions should occur:

- Remove load from trolley.
- Turn off/shut off or disconnect power supply.
- Secure trolley against unauthorized and unwarranted use.
- Do not walk in the path of a moving trolley, or walk backwards when moving a trolley.

■ Plain (Non-Powered) Trolley

1. To move an unloaded hoist/trolley, **push** on the hoist load chain.
2. To move a loaded hoist/trolley, **push** on the load or the hoist load hook shank.

■ Hand Chain (Geared) Trolley

When facing the handwheel side of the trolley, pulling down on the right hand chain fall will move the trolley to the left.

Pulling down on the left hand chain fall will move the trolley to the right.

■ Powered Trolley

■ *Pendant Operation*

The pendant is a remote control that allows the operator to control the positioning of a load. The pendant can have from two to six functions. The two-function pendant will control trolley movement in both directions. A four-function pendant will control trolley movement along the support beam and hoist operation. A six-function pendant would include the above movements plus control a bridge assembly allowing hoist movement in four directions. Always apply smooth even pressure to pendant levers/buttons, avoid quick starts and abrupt stops. This will allow smoother control of suspended loads and reduce undue stress on components.

■ Operating In Cold Weather

Cold weather operation can present additional hazards. At very cold temperatures metal can become brittle. Use extreme care to ensure that load movements are smooth and even. Lubricating fluids do not flow as readily. Make every effort to warm all fluids and components before operation. Run trolley slowly in both directions with no load to initially lubricate components.

Operators will also be wearing increased clothing so operation, feel of controls, field of vision and hearing could be impaired. Ensure that additional personnel/signalperson are used to maintain a safe operation.

WARNING

- **Avoid sudden loading and erratic control operation.**

Whenever temperature is below freezing, 32° F (0° C), extreme caution must be exercised to ensure that no part of trolley, supporting structure or suspended load is shock loaded or impacted as brittle fracture of steel may result.

Optional low temperature trolleys are available. Refer to model number on data (name) plate and trolley model code for approved operating temperature ranges.

■ Initial Operating Checks

Trolleys are tested for proper operation prior to leaving the factory. Before the trolley is placed in service the following initial operating checks should be performed.

1. Ensure power supply connections are tight and connected correctly.
2. When first running the trolley motors, some light oil should be injected into the inlet connection to allow good lubrication.
3. When first operating the hoist and trolley it is recommended that the motors be driven slowly in both directions for a few minutes.
4. Inspect hoist and trolley performance when raising, moving and lowering test loads. Hoist and trolley must operate smoothly and at rated specifications prior to being placed in service.
5. Check that trolley and hook movement is in the same direction as arrows and pendant control labels.
6. Check trolley rail stops are securely installed.
7. Ensure hoist is securely connected to trolley.

WARNING

- **Allow only personnel trained in safety and operation of this product to operate hoist and trolley.**

■ Optional Features

■ *Rope Control (Powered Trolleys)*

The rope control provides the operator with a local hoist operating station. The following directions are as viewed from the motor end of the hoist, facing the rope control.

1. To move a load to the right, pull down on the right rope.
2. To move a load to the left, pull down on the left rope.
3. Pull rope to full travel for maximum speed. Pull rope partially for slower speeds.
4. To stop movement, release rope. Trolley motor will stop.

PRODUCT INFORMATION GRAPHICS

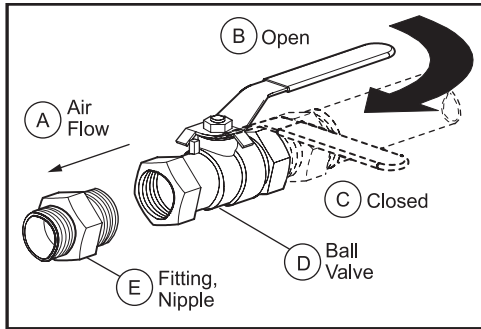

(Dwg. MHP2459)

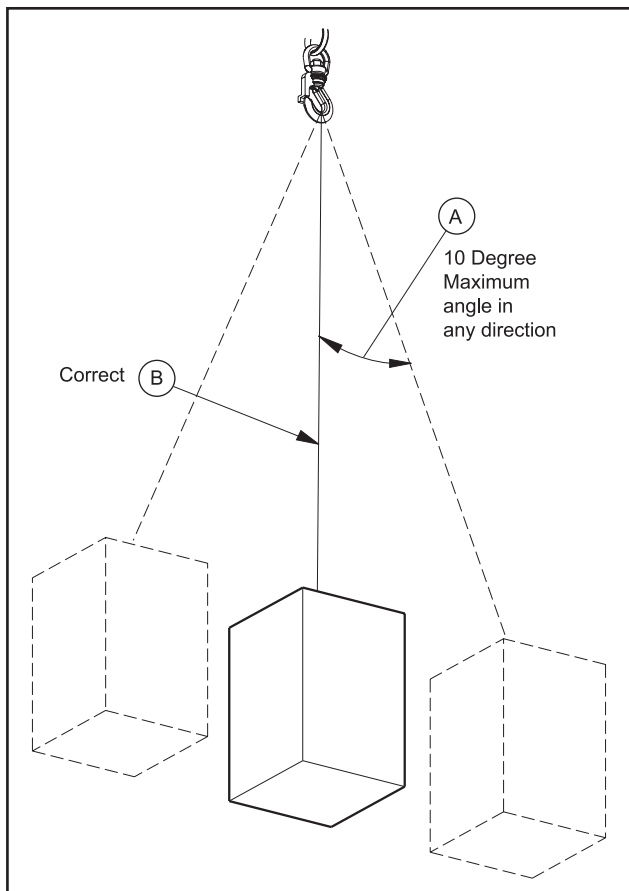

(Dwg. MHP2649)

SERVICE NOTES

SERVICE NOTES

SERVICE NOTES

