

OPERATOR'S MANUAL

50XX-XX

INCLUDING: APPLICATION, LUBRICATION, INSTALLATION & SERVICE

RELEASED: 6-1-82

REVISED: 2-20-01

(REV. A)

50 SERIES VALVES



**READ THIS MANUAL CAREFULLY BEFORE INSTALLING,
OPERATING OR SERVICING THIS EQUIPMENT.**

It is the responsibility of the employer to place this information in the hands of the operator. Keep for future reference.



Rated Pressure: 150 PSI (10.2 Bar) Maximum
Temperature Ratings: -10° to 180° F (-23° to 82° C)

Flow: 16 SCFM
Cv Factor : .43 Cv

MODEL DESCRIPTION CHART

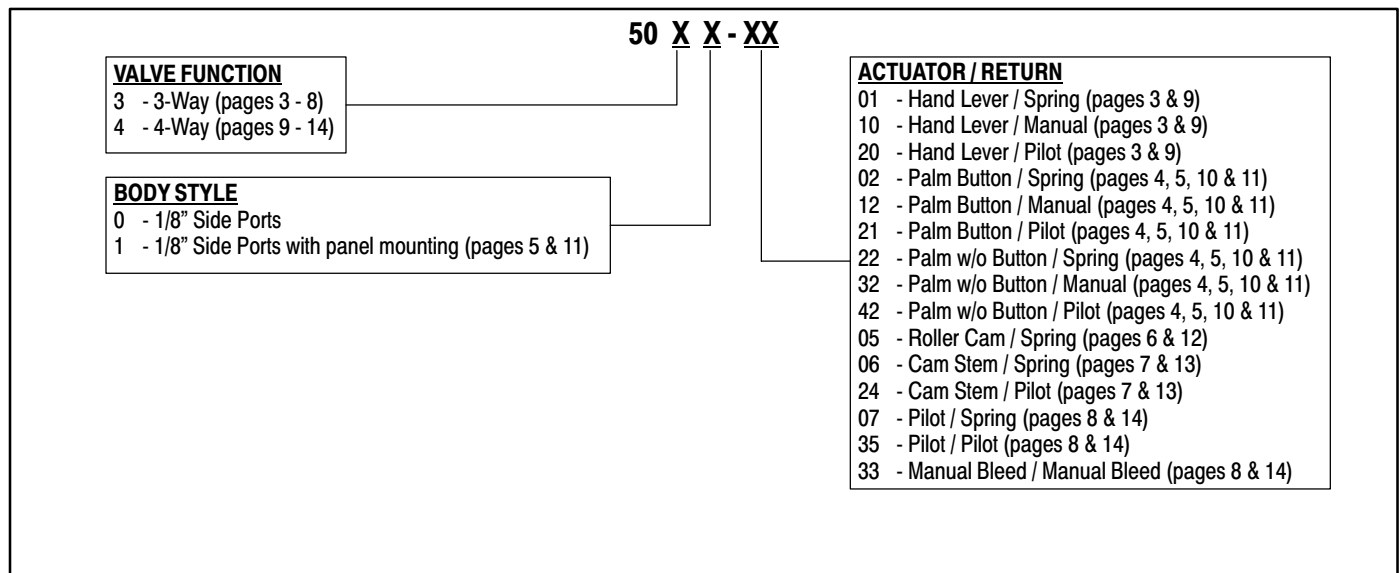

Warnings and Cautions

APPLICATION

WARNINGS:

1. ARO valves are designed for use only in industrial pneumatic (air) systems applications and are NOT to be used for individual consumer use, application or service.
2. When any ARO valve is used in any type application, safeguards must be provided to insure against bodily injury for the operator and / or other persons in the immediate area.
3. ARO valves are NOT to be used as a safety device or to operate and / or control the operation of full revolution clutch systems and / or brake systems on power presses or similar equipment. ARO valves are not designed or intended for such uses.

LUBRICATION

Lubrication is required with ARO "50" Series Valves for optimum performance. ARO recommends using a Filter-Regulator-Lubricator combination unit to maintain proper lubrication for the valves and other air line devices used in conjunction with ARO valves that require lubrication. Refer to ARO Catalog A-8531-R to select a Filter-Regulator-Lubricator combination unit of proper capacity for the system being used. To insure that lubrication oils are compatible with the valve seals and are of sufficient viscosity to assure adequate lubrication, Aro recommends an oil lubricant with a viscosity of 100 - 200 SUS at 100° F and an aniline point above 200° F. Aro does not recommend the use of compound oils containing graphite fillers, extremely low viscosities and other non-fluidic lubricants. RECOMMENDED: Aro 29665 air line lubricator oil is available in one quart containers.

INSTALLATION AND SERVICE

WARNINGS:

1. Shut off, disconnect and exhaust air pressure from system before installing or performing service to any ARO valve.
2. Shut off and disconnect electrical supply to system before installing or performing service to any ARO valve.
3. Allow only persons with a thorough understanding of the operation and application of all ARO valves being used in a particular system and how the ARO valve(s) relate to and interact with other components of the system to install or perform maintenance or service to any ARO valve or other components of the system.
4. DO NOT subject any ARO valve to any condition that exceeds the limits set forth in the specifications for a particular valve model.
5. When a manually operated (actuated) valve is used or installed into a system, provisions must be made to prevent the valve from being accidentally operated (actuated), which may in turn cause bodily injury or otherwise cause a hazardous or dangerous condition.
6. Damaged air pressure hoses or electrical wiring, or connections, can cause accidental valve operation (actuation), which may in turn cause bodily injury or otherwise cause a hazardous or dangerous condition. KEEP ALL HOSES, ELECTRICAL WIRING, FITTINGS AND CONNECTIONS IN FIRST CLASS OPERATING CONDITION.
7. **ARO 2-POSITION, 4-WAY VALVES:** Regardless of which of the 2-positions this type of ARO valve is in, when air pressure is applied to the inlet port(s) of these valves, there will always be an open flow path of air from the inlet to one of the valve outlets. A method to exhaust this trapped air pressure must be installed into the system so all air pressure can be removed from valve or system before performing service or maintenance to valve.

PARTS LIST

SERIES 50 SPOOL VALVES

1/8" N.P.T.F. PIPE PORTS

3-WAY, HAND LEVER

MODELS: 5030-01
5030-10
5030-20

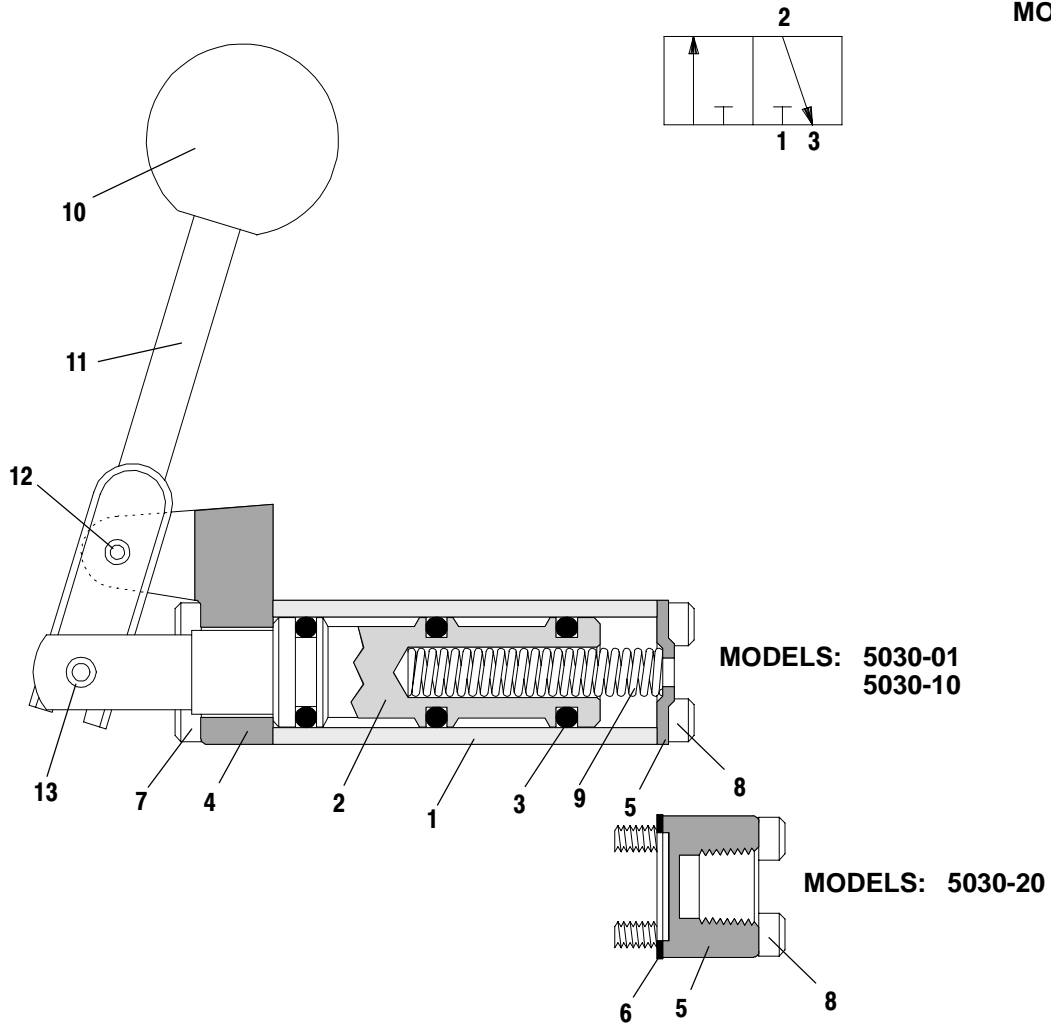

MODELS: 5030-01
5030-10

MODELS: 5030-20

PARTS LIST

ITEM	DESCRIPTION (Size in Inches)	QTY	PART NO.	ITEM	DESCRIPTION (Size in Inches)	QTY	PART NO.
1	Body	(1)	115311	8	Screw (#6 - 32 x 3/8") (5030-01, 5030-10)	(4)	Y195-33-C
2	Spool	(1)	115315		Screw (#6 - 32 x 3/4") (5030-20)	(4)	Y195-36-C
* 3	"O" Ring	(3)	15066	* 9	Spring (5030-01)	(1)	13006
4	Clevis End Plate	(1)	13508	10	Knob	(1)	13512-A
5	End Plate (5030-01, 5030-10)	(1)	14008	11	Handle	(1)	115642
	End Plate (5030-20)	(1)	14208	* 12	Roll Pin (1/8" o.d. x 1/2" long)	(1)	Y178-37-S
* 6	Gasket (5030-20)	(1)	14002	* 13	Roll Pin (5/32" o.d. x 7/16" long)	(1)	Y178-138
7	Screw (#6 - 32 x 3/4")	(4)	Y195-36-C	*	Repair Kit		7000

PARTS LIST

SERIES 50 SPOOL VALVES

1/8" N.P.T.F. PIPE PORTS

3-WAY, PALM BUTTON

MODELS: 5030-02 5030-22
 5030-12 5030-32
 5030-21 5030-41

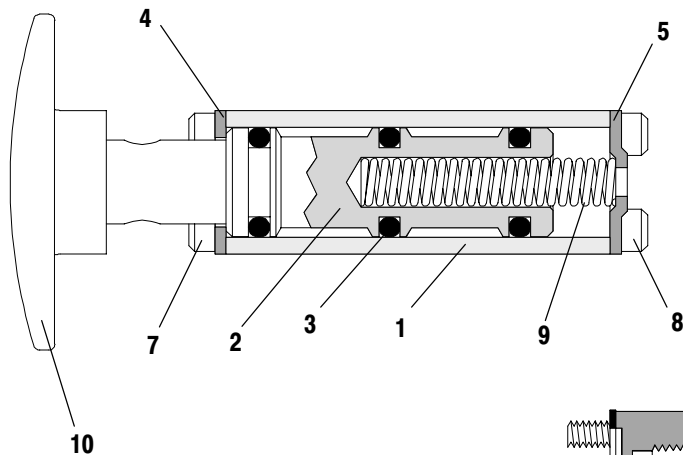
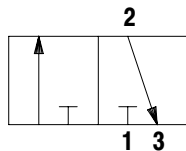

MODELS: 5030-02
 5030-12
 5030-22
 5030-32

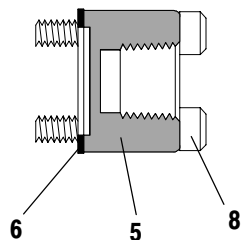

MODELS: 5030-21
 5030-41

PARTS LIST

ITEM	DESCRIPTION (Size in Inches)	QTY	PART NO.
1	Body	(1)	115311
2	Spool	(1)	115316
* 3	"O" Ring	(3)	15066
4	End Plate	(1)	14007
5	End Plate (5030-02, 5030-12, 5030-22, 5030-32)	(1)	14008
	End Plate (5030-21, 5030-41)	(1)	14208
* 6	Gasket (5030-21, 5030-41)	(1)	14002

ITEM	DESCRIPTION (Size in Inches)	QTY	PART NO.
7	Screw (#6 - 32 x 3/8")	(4)	Y195-33-C
8	Screw (#6 - 32 x 3/8") (5030-02, -12, -22, -32)	(4)	Y195-33-C
	Screw (#6 - 32 x 3/4") (5030-21, 5030-41)	(4)	Y195-36-C
* 9	Spring (5030-02, 5030-22)	(1)	13006
10	Palm Button (5030-02, 5030-12, 5030-21)	(1)	13111
*	Repair Kit		7000

PARTS LIST

SERIES 50 SPOOL VALVES

1/8" N.P.T.F. PIPE PORTS

3-WAY, PALM BUTTON (PANEL MOUNT)

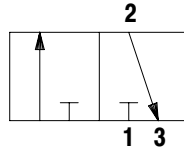

MODELS: 5031-02 5031-22
 5031-12 5031-32
 5031-21 5031-41

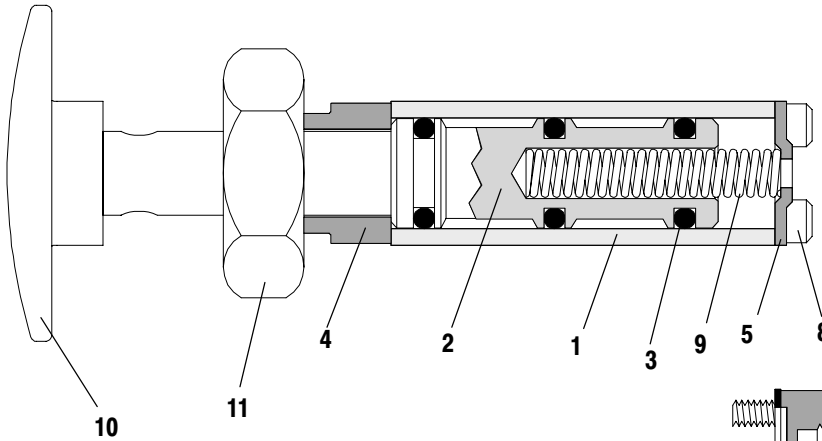

MODELS: 5031-02
 5031-12
 5031-22
 5031-32

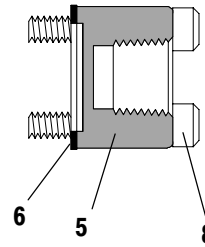

MODELS: 5031-21
 5031-41

PARTS LIST

ITEM	DESCRIPTION (Size in Inches)	QTY	PART NO.	ITEM	DESCRIPTION (Size in Inches)	QTY	PART NO.
1	Body	(1)	116031	7	Screw (#6 - 32 x 1/2") (not shown)	(4)	Y195-34-C
2	Spool	(1)	116030	8	Screw (#6 - 32 x 3/8") (5031-02, -12, -22, -32)	(4)	Y195-33-C
* 3	"O" Ring	(3)	15066		Screw (#6 - 32 x 3/4") (5031-21, 5031-41)	(4)	Y195-36-C
4	End Plate	(1)	116029	* 9	Spring (5031-02, 5031-22)	(1)	13006
5	End Plate (5031-02, 5031-12, 5031-22, 5031-32)	(1)	14008	10	Palm Button (5031-02, 5031-12, 5031-21)	(1)	13111
	End Plate (5031-21, 5031-41)	(1)	14208	11	Nut (3/4" - 16)	(1)	Y11-112-C
* 6	Gasket (5031-21, 5031-41)	(1)	14002	*	Repair Kit		7000

PARTS LIST

SERIES 50 SPOOL VALVES

1/8" N.P.T.F. PIPE PORTS

3-WAY, ROLLER CAM

MODELS: 5030-05

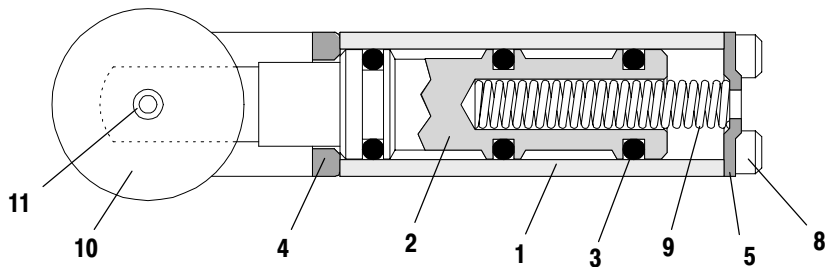
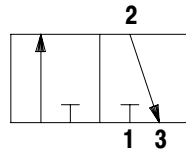

PARTS LIST

ITEM	DESCRIPTION (Size in Inches)	QTY	PART NO.	ITEM	DESCRIPTION (Size in Inches)	QTY	PART NO.
1	Body	(1)	115311	8	Screw (#6 - 32 x 3/8")	(4)	Y195-33-C
2	Spool	(1)	115315	* 9	Spring	(1)	13006
* 3	"O" Ring	(3)	15066	10	Roller Cam	(1)	20164
4	End Plate	(1)	13510	* 11	Roll Pin (5/32" o.d. x 7/16" long)	(1)	Y178-138
5	End Plate	(1)	14008	*	Repair Kit		7000
7	Screw (#6 - 32 x 1") (not shown)	(4)	Y195-38-C				

PARTS LIST

SERIES 50 SPOOL VALVES

1/8" N.P.T.F. PIPE PORTS

3-WAY, CAM STEM

MODELS: 5030-06
5030-24

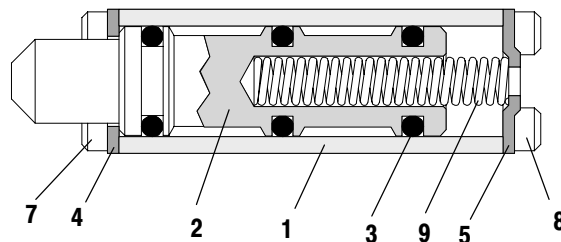
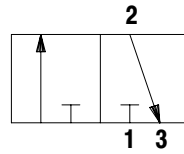

MODELS: 5030-06

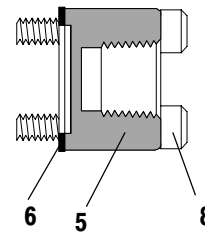

MODELS: 5030-24

PARTS LIST

ITEM	DESCRIPTION (Size in Inches)	QTY	PART NO.	ITEM	DESCRIPTION (Size in Inches)	QTY	PART NO.
1	Body	(1)	115311	* 6	Gasket (5030-24)	(1)	14002
2	Spool	(1)	115317	7	Screw (#6 - 32 x 3/8")	(4)	Y195-33-C
* 3	"O" Ring	(3)	15066	8	Screw (#6 - 32 x 3/8") (5030-06)	(4)	Y195-33-C
4	End Plate	(1)	14007		Screw (#6 - 32 x 3/4") (5030-24)	(4)	Y195-36-C
5	End Plate (5030-06)	(1)	14008	* 9	Spring (5030-06)	(1)	13006
	End Plate (5030-24)	(1)	14208	*	Repair Kit		7000

PARTS LIST

SERIES 50 SPOOL VALVES

1/8" N.P.T.F. PIPE PORTS

3-WAY, PILOT & MANUAL BLEED

MODELS: 5030-07
5030-35
5030-33

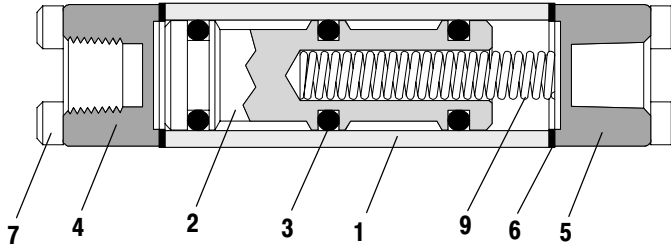
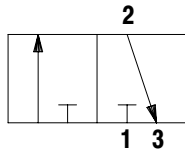

MODELS: 5030-07

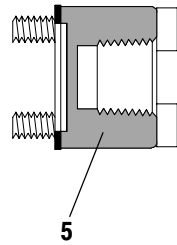

MODELS: 5030-35

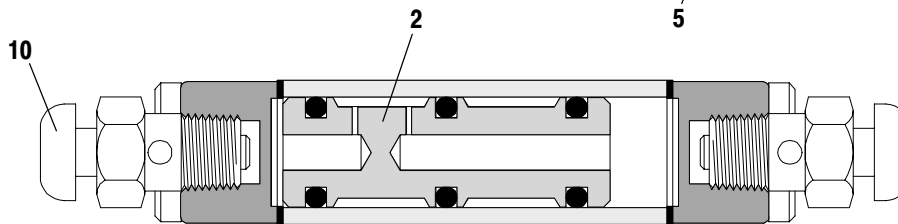

MODELS: 5030-33

PARTS LIST

ITEM	DESCRIPTION (Size in Inches)	QTY	PART NO.
1	Body	(1)	115311
2	Spool (5030-07)	(1)	115313
	Spool (5030-35)	(1)	115312
	Spool (5030-33)	(1)	115314
* 3	"O" Ring	(3)	15066
4	Clevis End Plate	(1)	14208

ITEM	DESCRIPTION (Size in Inches)	QTY	PART NO.
5	End Plate (5030-07)	(1)	14208-Z
	End Plate (5030-35, 5030-33)	(1)	14208
* 6	Gasket	(2)	14002
7	Screw (#6 - 32 x 3/4")	(8)	Y195-36-C
* 9	Spring (5030-07)	(1)	13006
10	Button Bleeder Assembly (5030-33)	(2)	24130
*	Repair Kit		7000

PARTS LIST

SERIES 50 SPOOL VALVES

1/8" N.P.T.F. PIPE PORTS

4-WAY, HAND LEVER

MODELS: 5040-01
5040-10
5040-20

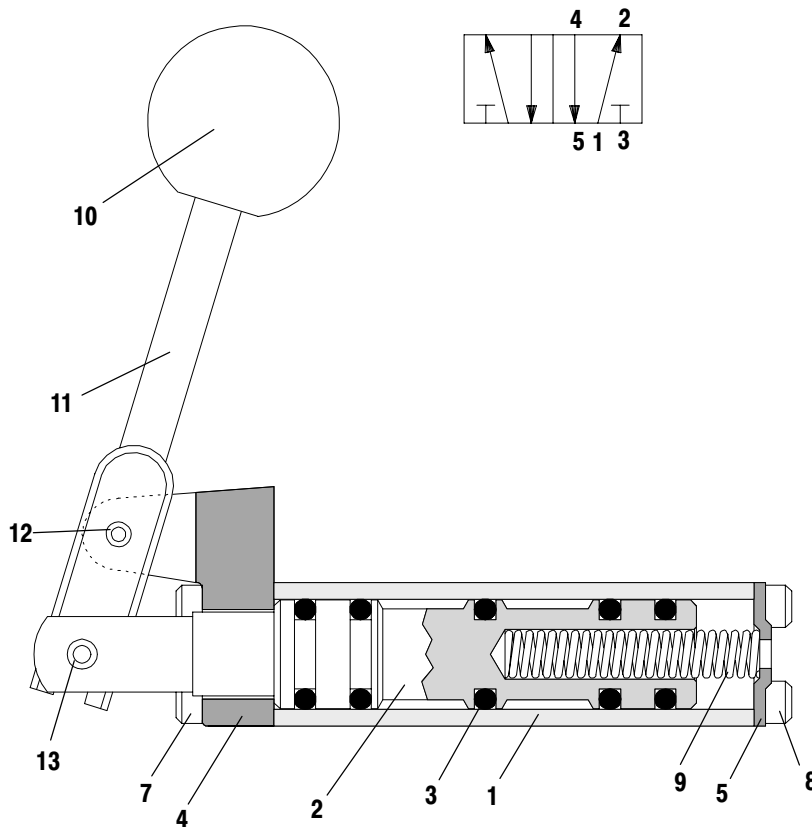

MODELS: 5040-01
5040-10

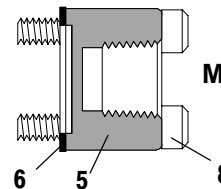

MODELS: 5040-20

PARTS LIST

ITEM	DESCRIPTION (Size in Inches)	QTY	PART NO.	ITEM	DESCRIPTION (Size in Inches)	QTY	PART NO.
1	Body	(1)	115318	8	Screw (#6 - 32 x 3/8") (5040-01, 5040-10)	(4)	Y195-33-C
2	Spool	(1)	115322		Screw (#6 - 32 x 3/4") (5040-20)	(4)	Y195-36-C
* 3	"O" Ring	(5)	15066	* 9	Spring (5040-01)	(1)	13006
4	Clevis End Plate	(1)	13508	10	Knob	(1)	13512-A
5	End Plate (5040-01, 5040-10)	(1)	14008	11	Handle	(1)	115642
	End Plate (5040-20)	(1)	14208	* 12	Roll Pin (1/8" o.d. x 1/2" long)	(1)	Y178-37-S
* 6	Gasket (5040-20)	(1)	14002	* 13	Roll Pin (5/32" o.d. x 7/16" long)	(1)	Y178-138
7	Screw (#6 - 32 x 3/4")	(4)	Y195-36-C	*	Repair Kit		7000

PARTS LIST

SERIES 50 SPOOL VALVES

1/8" N.P.T.F. PIPE PORTS

4-WAY, PALM BUTTON

MODELS: 5040-02 5040-22
 5040-12 5040-32
 5040-21 5040-41

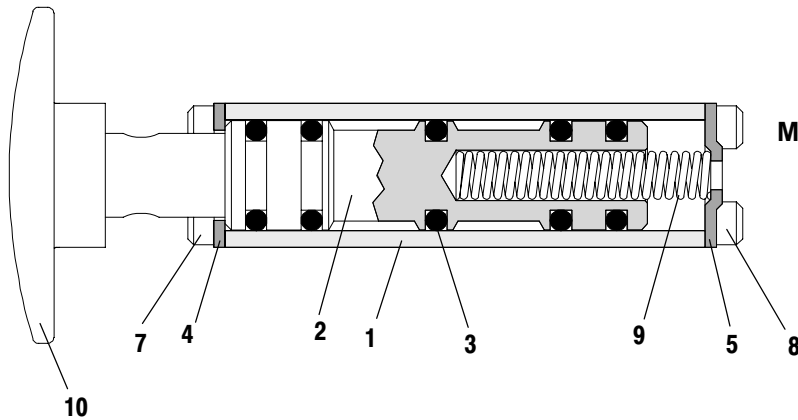
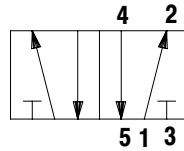

MODELS: 5040-02
 5040-12
 5040-22
 5040-32

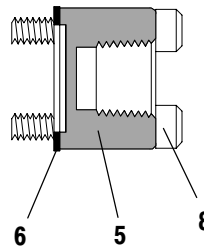

MODELS: 5040-21
 5040-41

PARTS LIST

ITEM	DESCRIPTION (Size in Inches)	QTY	PART NO.
1	Body	(1)	115318
2	Spool	(1)	115323
* 3	"O" Ring	(5)	15066
4	End Plate	(1)	14007
5	End Plate (5040-02, 5040-12, 5040-22, 5040-32)	(1)	14008
	End Plate (5040-21, 5040-41)	(1)	14208
* 6	Gasket (5040-21, 5040-41)	(1)	14002

ITEM	DESCRIPTION (Size in Inches)	QTY	PART NO.
7	Screw (#6 - 32 x 3/8")	(4)	Y195-33-C
8	Screw (#6 - 32 x 3/8") (5040-02, -12, -22, -32)	(4)	Y195-33-C
	Screw (#6 - 32 x 3/4") (5040-21, 5040-41)	(4)	Y195-36-C
* 9	Spring (5040-02, 5040-22)	(1)	13006
10	Palm Button (5040-02, 5040-12, 5040-21)	(1)	13111
*	Repair Kit		7000

PARTS LIST

SERIES 50 SPOOL VALVES

1/8" N.P.T.F. PIPE PORTS

4-WAY, PALM BUTTON (PANEL MOUNT)

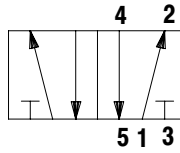

MODELS: 5041-02 5041-22
 5041-12 5041-32
 5041-21 5041-41

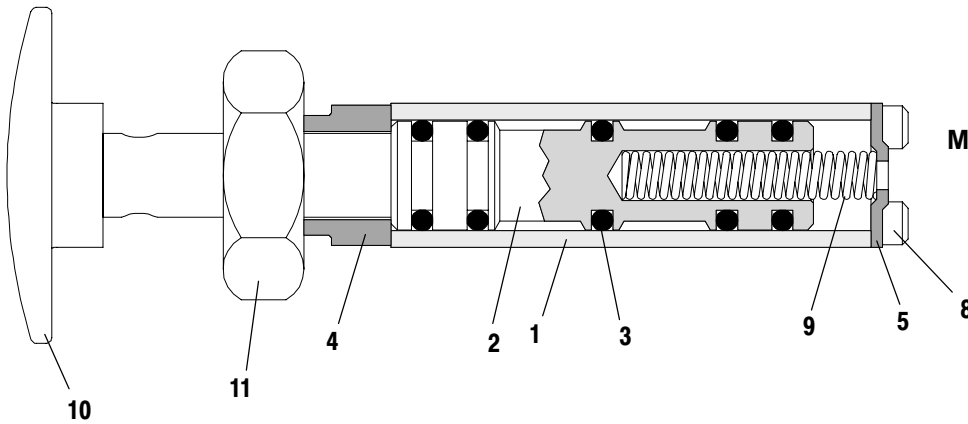

MODELS: 5041-02
 5041-12
 5041-22
 5041-32

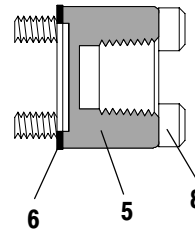

MODELS: 5041-21
 5041-41

PARTS LIST

ITEM	DESCRIPTION (Size in Inches)	QTY	PART NO.	ITEM	DESCRIPTION (Size in Inches)	QTY	PART NO.
1	Body	(1)	116033	7	Screw (#6 - 32 x 1/2") (not shown)	(4)	Y195-34-C
2	Spool	(1)	116032	8	Screw (#6 - 32 x 3/8") (5041-02, -12, -22, -32)	(4)	Y195-33-C
* 3	"O" Ring	(5)	15066		Screw (#6 - 32 x 3/4") (5041-21, 5041-41)	(4)	Y195-36-C
4	End Plate	(1)	116029	* 9	Spring (5041-02, 5041-22)	(1)	13006
5	End Plate (5041-02, 5041-12, 5041-22, 5041-32)	(1)	14008	10	Palm Button (5041-02, 5041-12, 5041-21)	(1)	13111
	End Plate (5041-21, 5041-41)	(1)	14208	11	Nut (3/4" - 16)	(1)	Y11-112-C
* 6	Gasket (5041-21, 5041-41)	(1)	14002	*	Repair Kit		7000

PARTS LIST

SERIES 50 SPOOL VALVES

1/8" N.P.T.F. PIPE PORTS

4-WAY, ROLLER CAM

MODELS: 5040-05

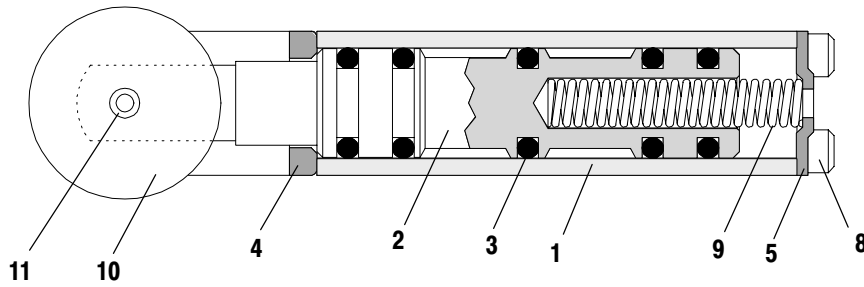
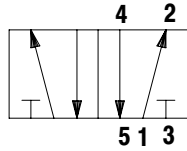

PARTS LIST

ITEM	DESCRIPTION (Size in Inches)	QTY	PART NO.
1	Body	(1)	115318
2	Spool	(1)	115322
* 3	"O" Ring	(5)	15066
4	End Plate	(1)	13510
5	End Plate	(1)	14008
7	Screw (#6 - 32 x 1") (not shown)	(4)	Y195-38-C

ITEM	DESCRIPTION (Size In Inches)	QTY	PART NO.
8	Screw (#6 - 32 x 3/8")	(4)	Y195-33-C
* 9	Spring	(1)	13006
10	Roller Cam	(1)	20164
* 11	Roll Pin (5/32" o.d. x 7/16" long)	(1)	Y178-138
*	Repair Kit		7000

PARTS LIST

SERIES 50 SPOOL VALVES

1/8" N.P.T.F. PIPE PORTS

4-WAY, CAM STEM

MODELS: 5040-06
5040-24

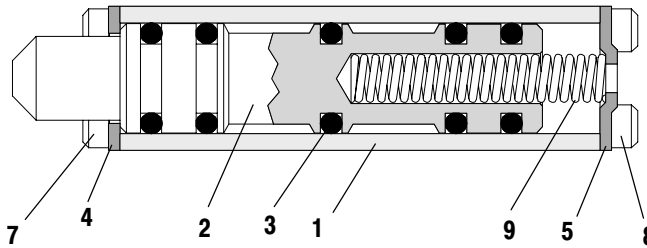
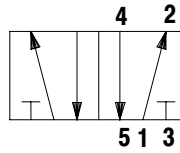

MODELS: 5040-06

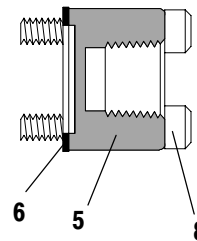

MODELS: 5040-24

PARTS LIST

ITEM	DESCRIPTION (Size in Inches)	QTY	PART NO.		ITEM	DESCRIPTION (Size In Inches)	QTY	PART NO.
1	Body	(1)	115318		* 6	Gasket (5040-24)	(1)	14002
2	Spool	(1)	115324		7	Screw (#6 - 32 x 3/8")	(4)	Y195-33-C
* 3	"O" Ring	(5)	15066		8	Screw (#6 - 32 x 3/8") (5040-06)	(4)	Y195-33-C
4	End Plate	(1)	14007			Screw (#6 - 32 x 3/4") (5040-24)	(4)	Y195-36-C
5	End Plate (5040-06)	(1)	14008		* 9	Spring (5040-06)	(1)	13006
	End Plate (5040-24)	(1)	14208		*	Repair Kit		7000

PARTS LIST

SERIES 50 SPOOL VALVES

1/8" N.P.T.F. PIPE PORTS

4-WAY, PILOT & MANUAL BLEED

MODELS: 5040-07
5040-35
5040-33

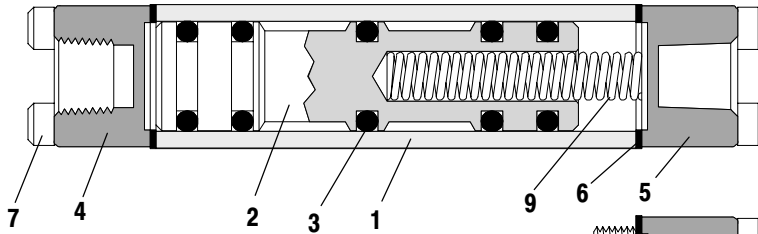
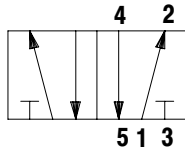

MODELS: 5040-07

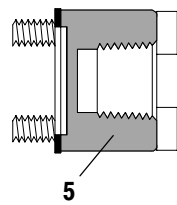

MODELS: 5040-35

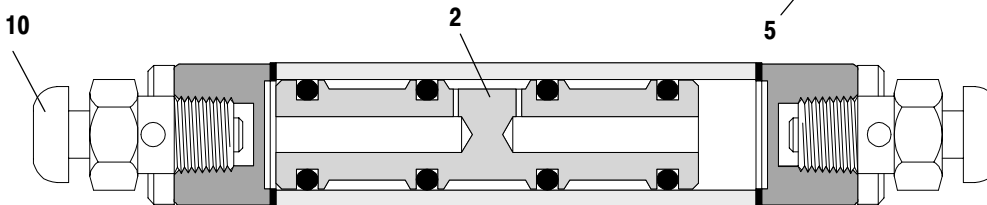

MODELS: 5040-33

PARTS LIST

ITEM	DESCRIPTION (Size in Inches)	QTY	PART NO.	ITEM	DESCRIPTION (Size in Inches)	QTY	PART NO.
1	Body	(1)	115318	5	End Plate (5040-07)	(1)	14208-Z
2	Spool (5040-07)	(1)	115320		End Plate (5040-35, 5040-33)	(1)	14208
	Spool (5040-35)	(1)	115319	* 6	Gasket	(2)	14002
	Spool (5040-33)	(1)	115321	7	Screw (#6 - 32 x 3/4")	(8)	Y195-36-C
* 3	"O" Ring (5040-07, 5040-35)	(5)	15066	* 9	Spring (5040-07)	(1)	13006
*	"O" Ring (5040-33)	(4)	15066	10	Button Bleeder Assembly (5040-33)	(2)	24130
4	Clevis End Plate	(1)	14208	*	Repair Kit		7000

