

611170 HAND OPERATED LUBRICATION PUMP



READ THIS MANUAL CAREFULLY BEFORE INSTALLING, OPERATING OR SERVICING THIS EQUIPMENT.

It is the responsibility of the employer to place this information in the hands of the operator. Keep for future reference.

OPERATING PRECAUTIONS

Use ARO replacement parts to assure compatible pressure rating. Read all Warnings and Safety Instructions carefully before operation of this unit.

⚠ WARNING PREVENT STATIC SPARKING. If static sparking occurs, fire or explosion could result. Pump dispensing valve, and containers must be grounded when handling inflammable fluids such as petroleum products, paints, lacquers, etc. and whenever discharge of static electricity is a hazard.

⚠ CAUTION When pumping, flushing or recirculating volatile solvents, the area must be adequately ventilated.

⚠ CAUTION Keep solvents away from heat, sparks and open flames. Keep container closed when not in use.

⚠ CAUTION Materials and Solvents being pumped must be compatible with the parts of the pump that become wetted when in contact with material or solvent.

RATIO ADJUSTMENT

The Aro multi-purpose hand operated pumps are designed so the ratio can be easily adjusted to handle fluids of any viscosity.

The lower the ratio is set, the more volume of fluid will be dispensed with each stroke. The heavier the the viscosity of the fluid the higher the ratio should be and the volume per stroke will be reduced accordingly.

Use the ratio setting where the pump delivers the most volume and operates with the least effort.

The diagram in figure 2 illustrates the location of the linkage to obtain any one of the three different ratios.

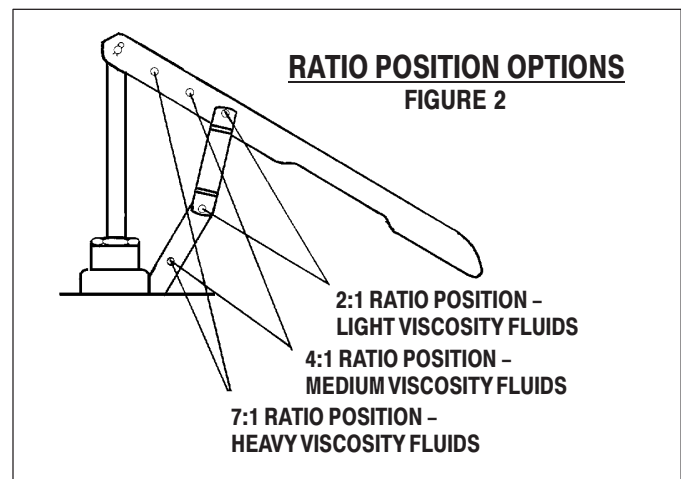
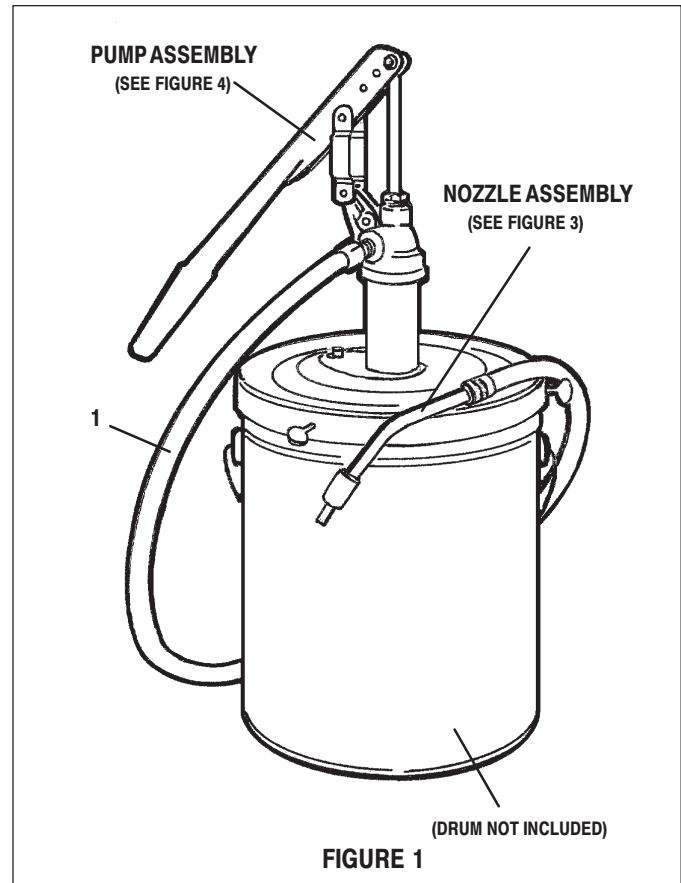

GENERAL INFORMATION

INSTALLATION

1. Screw the (1) hose and nozzle assembly into the (16) pump body. Be sure all threads are tight.
2. Remove the (18) pump holder, (19) grommet, (20) clevis pin, (21) hair pin retainer from the parts bag.
3. Put the (20) clevis pin through the small hole in the (18) pump holder and then through the small hole in the (17) drum cover.
4. Hold in this position and turn (17) drum cover assembly over, now put the (21) hair pin retainer through the (20) clevis pin to secure it in place. Long nose pliers are helpful at this point.
5. Line up large hole in (18) pump holder with large hole in (17) drum cover assembly and slip the (19) grommet into place in (18) pump holder (see drawing).
6. Depress the (18) pump holder and slip the (17) drum cover assembly over the (31) suction tube of pump. Adjust to desired height and secure by releasing (18) pump holder.
7. Remove the (10) link pin, (11) link pins, (12) hair pin retainer and (13) link from bag. Install (8) hand lever onto the top of the (24) piston rod using (10) link pin and use (12) hair pin retainer. The last hole in the end of the (8) hand lever should be used. The (9) link and pins assembly attaches to the (16) pump body and the top end of the (9) link and pins assembly connects to setting on the (8) hand lever as shown in figures 2 and 4. **Always install the (13) link so that the arrow on the side points upward.** Be sure the cross-pin in the link is "UP" next to the handle. Other ratios may be had by assembling the (13) link according to the number stamped on the pump (8) hand lever.

TROUBLE SHOOTING

- If the pumps fails to operate, the ratio setting may be too low for the material being pumped. If this is not the cause, check suction tube for damage or obstruction.
- If the pump operates, but dispenses little or no material, remove the foot valve assembly and check for foreign matter which may be holding the valve plate off the seat. Also, make sure the valve plate or seat is not bent or scored.
- If leakage occurs between plunger rod and gland, tighten nut just enough to stop leakage. Do not over tighten as this will cause excessive packing wear and harden pumping action.

MAINTENANCE

Disassembly should be done on a clean work bench with clean cloths to keep parts clean.

Periodically flush pump with a solvent that is compatible with material being pumped.

Caution should be used at all times to keep the material covered and free from contamination which could damage the piston rod assembly.

PARTS LIST

ITEM	Description	(Qty)	Part No.
1	Hose and Nozzle Assembly (includes items 2 thru 6)	(1)	621597-5
2	Tube	(1)	71559
3	Valve Body	(1)	71561
4	Seal	(1)	71560
5	Ball (9/32" dia)	(1)	Y16-209
6	Spring	(1)	F51-58
7	Seal	(1)	72056
8	Hand Lever	(1)	72001-1
9	Link and Pins Assembly (includes items 10 thru 13)	(1)	72062
10	Link Pin	(1)	72833
11	Link Pin	(2)	72834
12	Hair Pin Retainer	(3)	72835
13	Link	(1)	72027
14	Gland	(1)	72058
15	Seal	(2)	72021
16	Pump Body	(1)	72012
17	Drum Cover Assembly (includes items 18 thru 23)	(1)	72006

ITEM	Description	(Qty)	Part No.
18	Pump Holder	(1)	72052
19	Grommet	(1)	72047
20	Clevis Pin	(1)	94926
21	Hair Pin Retainer	(1)	72835
22	Thumb Screw (1/4" - 20 x 3/4")	(3)	Y66-55-C
23	Gasket	(1)	94925
24	Piston Rod	(1)	72022-1
25	Plate	(1)	72042
26	Seal	(1)	72061
27	Nut (3/8" - 24)	(1)	Y11-106-C
28	Spring	(1)	72018
29	Piston	(1)	72017
30	Lock Washer (3/8")	(1)	Y1-616-C
31	Suction Tube	(1)	72019-2
32	Intake Valve Assembly (includes items 33 thru 35)	(1)	72046
33	Plate	(1)	F58-2
34	Pin	(1)	71201
35	Intake Valve Body	(1)	72064-1

