

SALES & ENGINEERING DATA

RATIO SERIES: **1:1**

FLUID P.S.I. RANGE: **20 - 120**

PF20A-XXX-SXX-B & PF20S-XXX-SXX-B 2" METALLIC FLAP VALVE DIAPHRAGM PUMP

RELEASED: 2-10-05
REVISED: 6-10-10
(REV. 03) S-1342

DIMENSIONAL DATA

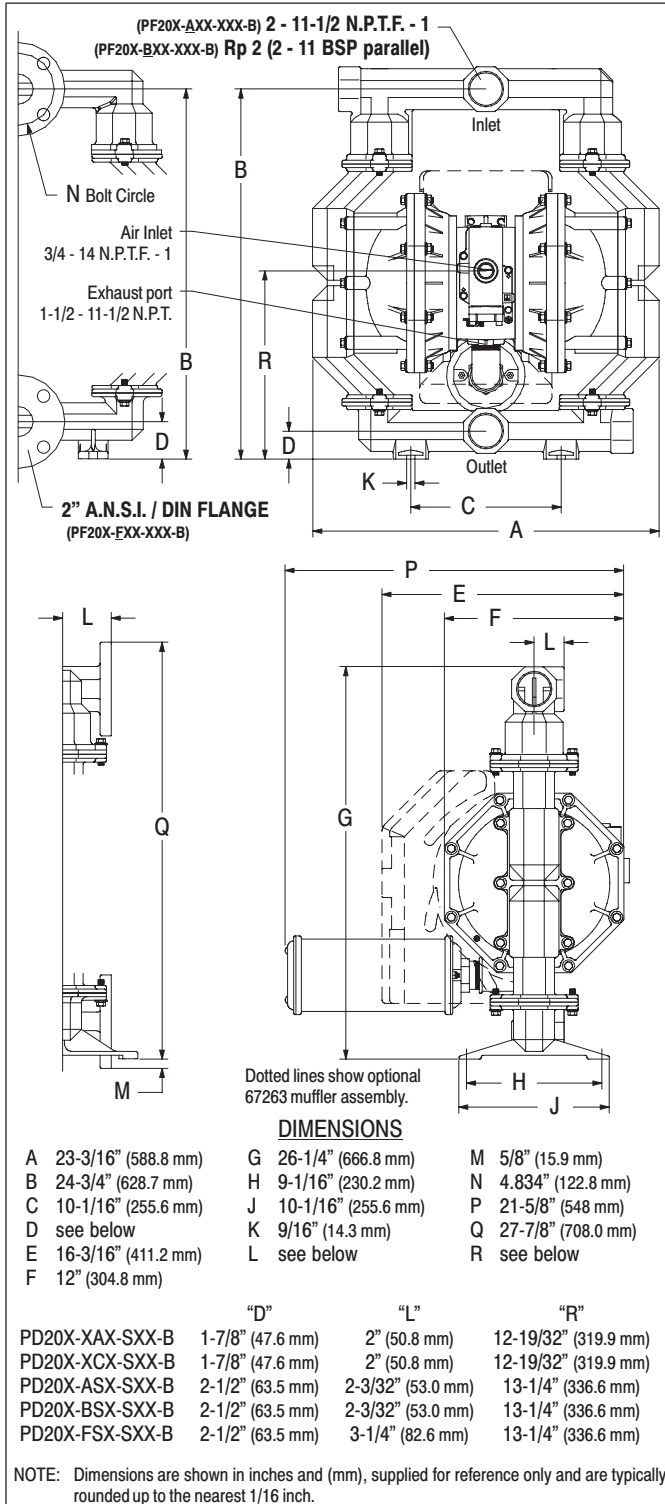

SPECIFICATIONS

CONSTRUCTION

Model Series	PF20A-XXX-SXX-B
	PF20S-XXX-SXX-B
Pump Type	Metallic, Air Operated, Flap Valve, Double Diaphragm
Ratio	1:1
Material Inlet / Outlet (female)	
PF20X-AXX-SXX-B	2 - 11-1/2 N.P.T.F. - 1
PF20X-BXX-SXX-B	Rp 2 (2 - 11 BSP parallel)
PF20X-FXX-SXX-B	2" A.N.S.I. / DIN Flange
Air Inlet (female)	3/4 - 14 N.P.T.F. - 1
Air Exhaust (female)	1-1/2 - 11-1/2 N.P.T.
Weight	
PF20A-XAX-SXX-B	97.3 lbs (44.2 kgs)
PF20A-XCX-SXX-B	166.2 lbs (75.4 kgs)
PF20A-ASX-SXX-B	166.0 (75.3 kgs)
PF20A-BSX-SXX-B	166.0 (75.3 kgs)
PF20A-FSX-SXX-B	177.1 (80.3 kgs)
	(add 28.9 lbs [13.1 kgs] for Stainless steel air motor section)
Air Section Service Kit	637421
Fluid Section Service Kit	637310-XX
Major Air Valve Assembly	637374-X

PF20X-XXX-S

X	X
X	X

 -B
637310 -

X	X
---	---

Diaphragm Material
Flap Material
EXAMPLE: Model # PF20A-AAP-SAA-B
Fluid Section Service Kit is 637310-AA

PERFORMANCE

Air Inlet Pressure Range	20 - 120 p.s.i. (1.4 - 8.3 bar)
Maximum Material Inlet Pressure	10 p.s.i. (0.69 bar)
Fluid Pressure Range	20 - 120 p.s.i. (1.4 - 8.3 bar)
Maximum Flow Rate	172 g.p.m. (651 l.p.m.)
Maximum Particle Size	2" dia. (50 mm) semi-solids
Maximum Temperature Limits (diaphragm / ball / seal material)	
E.P.R. / EPDM	-60° to 280° F (-51° to 138° C)
Nitrile	10° to 180° F (-12° to 82° C)
Polyurethane	10° to 150° F (-12° to 66° C)
Santoprene®	-40° to 225° F (-40° to 107° C)
PTFE	40° to 225° F (4° to 107° C)
Viton®	-40° to 350° F (-40° to 177° C)
Displacement / Cycle @ 100 p.s.i.	1.4 gal. (5.3 lit.)
Noise Level @ 70 p.s.i. - 60 c.p.m.①	85.0 db(A)②

① Tested with 67263 muffler assembly installed.
② The pump sound pressure level has been updated to an Equivalent Continuous Sound Level (L_{Aeq}) to meet the intent of ANSI S1. 13-1971, CAGI-PNEUROP S5.1 using four microphone locations.

ACCESSORIES:

- 66312 Air Line Connection Kit
- 67263 Continuous Muffler Assembly
- 94117 Int. Muffler

PERFORMANCE CURVES

PF20A-XXX-XXX-B / PF20S-XXX-XXX-B 2" METALLIC FLAP VALVE DIAPHRAGM PUMP

