

1/4" DIAPHRAGM PUMP 1:1 RATIO (NON-METALLIC)



**READ THIS MANUAL CAREFULLY BEFORE INSTALLING,
 OPERATING OR SERVICING THIS EQUIPMENT.**

It is the responsibility of the employer to place this information in the hands of the operator. Keep for future reference.

SERVICE KITS

Refer to Service Kit Chart to match the pump material with the service kits offered. The "X" represents a variable digit of the model number.

637276 air valve kit.

637313-XX for pump wet end repair (model digits 7 and 11).

637314-XX for pump rebuild (model digits 7 and 11).

PUMP DATA

Models see Model Description Chart for "-XXX"

Pump Type . . Non-Metallic Air Operated Double Diaphragm

Material see Model Description Chart

Weight PD02P-XPS-XXX 4.08 lbs (1.85 kgs)
 PD02P-XDS-XXX 4.64 lbs (2.10 kgs)
 PD02P-XKS-XXX 4.90 lbs (2.22 kgs)

Maximum Air Inlet Pressure 100 p.s.i.g. (6.9 bar)

Minimum Air Inlet Pressure 20 p.s.i.g. (1.4 bar)

Maximum Outlet Pressure 100 p.s.i.g. (6.9 bar)

Maximum Flow Rate 4.6 g.p.m. (17.4 l.p.m.)

Maximum Suction Lift 20 ft (water)

Maximum Output Per Cycle 0.014 gal. (53 cc's)

Maximum Particle Size clean fluid only

Maximum Temperature Limits (diaphragm / ball / seat material)

E.P.R. / EPDM	-60° to 280° F (-51° to 138° C)
Groundable Acetal	10° to 180° F (-12° to 82° C)
Kynar® PVDF	10° to 200° F (-12° to 93° C)
Nitrile	10° to 180° F (-12° to 82° C)
Polypropylene	35° to 175° F (2° to 79° C)
Santoprene®	-40° to 225° F (-40° to 107° C)
PTFE	40° to 225° F (4° to 107° C)

Groundable PD02P-XDS-DTX models only

Dimensional Data see page 8

Noise Level @ 70 p.s.i., 60 c.p.m. 59.8 db(A)①

① The pump sound pressure levels published here have been updated to an Equivalent Continuous Sound Level (L_{Aeq}) to meet the intent of ANSI S1.13-1971, CAGI-PNEUROP S5.1 using four microphone locations.

NOTICE: All possible options are shown in the chart, however, certain combinations may not be recommended, consult a representative or the factory if you have questions concerning availability.

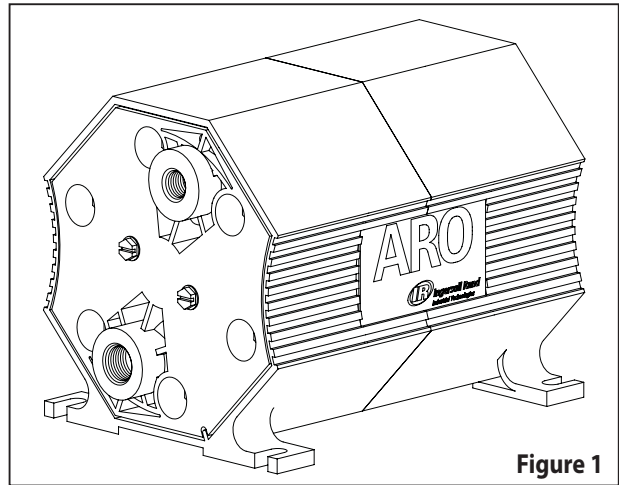

Figure 1

MODEL DESCRIPTION CHART

PD02 P - X X S - X T X

Center Body Material P - Polypropylene	
Inlet / Outlet A - Single Inlet / Single Outlet D - Single Inlet / Double Outlet E - Double Inlet / Single Outlet H - Double Inlet / Double Outlet	
Wet End / Fluid Cap / Manifold Material D - Groundable Acetal K - Kynar PVDF P - Polypropylene	
Hardware Material S - Stainless Steel	
Check Valve Seat Material D - Groundable Acetal K - Kynar PVDF P - Polypropylene	
Check Material T - PTFE	
Diaphragm / "O" Ring Material A - Santoprene / E.P.R. G - Nitrile / Nitrile T - PTFE / PTFE / Nitrile	
Fluid Section Service Kit Selection	PD02P - X X S - X T X
EXAMPLE: Model #PD02P-ADS-DTA	637313 - <input checked="" type="checkbox"/> X
Fluid Section Service Kit # 637313-DA	Wet End Material <input checked="" type="checkbox"/>
	Diaphragm Material <input checked="" type="checkbox"/>

OPERATING AND SAFETY PRECAUTIONS

READ, UNDERSTAND AND FOLLOW THIS INFORMATION TO AVOID INJURY AND PROPERTY DAMAGE.



EXCESSIVE AIR PRESSURE
STATIC SPARK



HAZARDOUS MATERIALS
HAZARDOUS PRESSURE

⚠ WARNING EXCESSIVE AIR PRESSURE. Can cause personal injury, pump damage or property damage.

- Do not exceed the maximum inlet air pressure as stated on the pump model plate.
- Be sure material hoses and other components are able to withstand fluid pressures developed by this pump. Check all hoses for damage or wear. Be certain dispensing device is clean and in proper working condition.

⚠ WARNING STATIC SPARK. Can cause explosion resulting in severe injury or death. Ground pump and pumping system.

- PD02P-XDS-DTX Groundable Acetal pumps: Use the pump grounding screw provided. A screw terminal is provided on the manifold. Connect a 12 ga. (minimum) wire (66885-1 kit is available) to a good earth ground source.
- The pumping system and object being sprayed must be grounded when it is pumping, flushing, recirculating or spraying flammable materials such as paints, solvents, lacquers, etc. or used in a location where surrounding atmosphere is conducive to spontaneous combustion.
- Secure pump, connections and all contact points to avoid vibration and generation of contact or static spark.
- Consult local building codes and electrical codes for specific grounding requirements.
- After grounding, periodically verify continuity of electrical path to ground. Test with an ohmmeter from each component (e.g., hoses, pump, clamps, container, spray gun, etc.) to ground to insure continuity. Ohmmeter should show 0.1 ohms or less.
- Submerge the outlet hose end, dispensing valve or device in the material being dispensed if possible. (Avoid free streaming of material being dispensed.)
- Use hoses incorporating a static wire.
- Use proper ventilation.
- Keep inflammables away from heat, open flames and sparks.
- Keep containers closed when not in use.

⚠ WARNING Pump exhaust may contain contaminants. Can cause severe injury. Pipe exhaust away from work area and personnel.

- In the event of a diaphragm rupture, material can be forced out of the air exhaust muffler.
- Pipe the exhaust to a safe remote location when pumping hazardous or inflammable materials.
- Use a grounded 1/4" minimum i.d. hose between the pump and the muffler.

⚠ WARNING HAZARDOUS PRESSURE. Can result in serious injury or property damage. Do not service or clean pump, hoses or dispensing valve while the system is pressurized.

- Disconnect air supply line and relieve pressure from the system by opening dispensing valve or device and / or carefully and slowly loosening and removing outlet hose or piping from pump.

⚠ WARNING HAZARDOUS MATERIALS. Can cause serious injury or property damage. Do not attempt to return a pump to the factory or service center that contains hazardous material. Safe handling practices must comply with local and national laws and safety code requirements.

- Obtain Material Safety Data Sheets on all materials from the supplier for proper handling instructions.

⚠ CAUTION Verify the chemical compatibility of the pump wetted parts and the substance being pumped, flushed or recirculated. Chemical compatibility may change with temperature and concentration of the chemical(s) within the substances being pumped, flushed or circulated. For specific fluid compatibility, consult the chemical manufacturer.

⚠ CAUTION Maximum temperatures are based on mechanical stress only. Certain chemicals will significantly reduce maximum safe operating temperature. Consult the chemical manufacturer for chemical compatibility and temperature limits. Refer to PUMP DATA on page 1 of this manual.

⚠ CAUTION Be certain all operators of this equipment have been trained for safe working practices, understand it's limitations, and wear safety goggles / equipment when required.

⚠ CAUTION Do not use the pump for the structural support of the piping system. Be certain the system components are properly supported to prevent stress on the pump parts.

- Suction and discharge connections should be flexible connections (such as hose), not rigid piped, and should be compatible with the substance being pumped.

⚠ CAUTION Prevent unnecessary damage to the pump. Do not allow pump to operate when out of material for long periods of time.

- Disconnect air line from pump when system sits idle for long periods of time.

⚠ CAUTION Use only genuine ARO® replacement parts to assure compatible pressure rating and longest service life.

NOTICE Replacement warning labels are available upon request: "Static Spark and Diaphragm Rupture" pn \ 94080.

⚠ WARNING = Hazards or unsafe practices which could result in severe personal injury, death or substantial property damage.

⚠ CAUTION = Hazards or unsafe practices which could result in minor personal injury, product or property damage.

NOTICE = Important installation, operation or maintenance information.

GENERAL DESCRIPTION

The ARO diaphragm pump offers high volume delivery even at low air pressures, easy self priming and the ability to pump various viscosity materials. The pump is designed to correspond to the needs of the user by offering a variety of wetted parts configurations to handle almost any application.

Air operated double diaphragm pumps utilize a pressure differential in the air chambers to alternately create suction and positive fluid pressure in the fluid chambers. Flat checks insure a positive flow of fluid.

Pump cycling will begin as air pressure is applied and it will continue to pump and keep up with the demand. It will build and maintain line pressure and will stop cycling once maximum line pressure is reached (dispensing device closed) and will resume pumping as needed.

Model PD02P-XDS-DTX: The Acetal material used in this pump contains stainless steel fibers. It's conductivity allows it to be connected to a suitable ground. A ground screw is provided for this.

AIR AND LUBE REQUIREMENTS

⚠ WARNING EXCESSIVE AIR PRESSURE. Can cause pump damage, personal injury or property damage.

- A filter capable of filtering out particles larger than 50 microns should be used on the air supply. In most applications there is no lubrication required other than the "O" ring lubricant which is applied during assembly or repair.
- The pump can be rotated 360° to suit the application. It may be mounted upside down or on the wall with no effect on suction lift or operating efficiency. The filter and regulator need to be oriented in a normal vertical direction to function properly.
- Pipe plugs are included for the material inlets. They can be switched to accommodate piping requirements. However, the fluid inlet must always be in the port closest to the mounting base.
- When lubricated air is necessary, supply the air lubricator with a good grade of SAE 90 wt. non-detergent oil and set the lubricator to a rate not to exceed one drop per minute.

INSTALLATION

- **NOTICE: Re-torque fasteners prior to use. Refer to step #18 on page 6 for information.**
- Apply PTFE tape or pipe sealant to threads upon assembly to prevent leakage.
- Secure the diaphragm pump legs to a suitable surface to insure against damage by vibration.
- To avoid problems, install a particle fluid filter to screen out foreign matter 1/32" (0.79 mm) or larger in diameter.
- The pump is not recommended for submerged applications.
- When the diaphragm pump is used in a forced-feed (flooded inlet) situation, it is recommended that a "Check Valve" be installed at the air inlet.

OPERATING INSTRUCTIONS

- Always flush the pump with a solvent compatible with the material being pumped if the material being pumped is subject to "setting up" when not in use for a period of time.
- Disconnect the air supply from the pump if it is to be inactive for a few hours.
- The outlet material volume is governed not only by the air supply, but also by the material supply available at the inlet. The material supply tubing should not be too small or restrictive. Be sure not to use hose which might collapse.

MAINTENANCE

Refer to the part list on page 4 for service kit information, parts view on page 5 and Repair Procedures on page 6.

- Certain ARO "Smart Parts" are indicated which should be available for fast repair and reduction of down time.
- Service kits are available to service two separate diaphragm pump functions: 1. AIR SECTION, 2. FLUID SECTION. The Fluid Section is divided further to match typical active Material Options.
- Provide a clean work surface to protect sensitive internal moving parts from contamination from dirt and foreign matter during service disassembly and reassembly.
- Keep good records of service activity and include the pump in preventive maintenance program.

PARTS LIST / PD02P-XXX-XXX

637276 Air Valve Kit: Includes items 102, 111, 132, 134, 135, 137, 145, 146, 178, 179 and 94276 Lubriplate packet.

637313-XX Diaphragm Kit: Includes items 7, 13, 19, 22, 33, 41, 64, 144, 147, 161 and 94276 Lubriplate packet.

637314-XX Rebuild Kit: Includes items 7, 13, 19, 22, 33, 41, 64, 102, 111, 119, 137, 144, 146, 147, 161 and 94276 Lubriplate packet.

DIAPHRAGM OPTIONS PD02P-XXX-XXX

-XX	"7"			"19"			"33" (0.103" x 0.693" o.d.)			"64" (0.157" x 3.424" o.d.)		
	Diaphragm	Qty	Mtl	Seal	Qty	Mtl	"O" Ring	Qty	Mtl	"O" Ring	Qty	Mtl
-XXA	93808	(2)	[Sp]	94434	(4)	[E]	94437	(2)	[E]	-----	---	---
-XXG	93808-G	(2)	[B]	94434-G	(4)	[B]	94438	(2)	[T]	-----	---	---
-XXT	93898	(2)	[T]	94435	(4)	[T]	94438	(2)	[T]	93497	(2)	[B]

COMMON PARTS

PD02P-XXS-XTX			Polypropylene PD02P-XPS-PTX		Groundable Acetal PD02P-XDS-DTX		Kynar PVDF PD02P-XKS-KTX	
Item	Description (size)	Qty	Part No.	Mtl	Part No.	Mtl	Part No.	Mtl
<input type="checkbox"/> 1	Rod (2-13/16" long)	(1)	93916	[C]	93916	[C]	93916	[C]
<input type="checkbox"/> 5	Washer (1-3/4" o.d.)	(2)	94938	[Z]	94938	[Z]	94938	[Z]
<input type="checkbox"/> 6	Diaphragm Screw (1/4" - 20)	(2)	93810-1	[P]	93810-2	[D1]	93810-3	[PK]
13	Back-Up Ring	(2)	95127	[T]	95127	[T]	95127	[T]
17	Manifold - Air Inlet	(1)	94246-1	[P]	94246-2	[GA]	94246-4	[PK]
18	Manifold	(1)	94247-1	[P]	94247-2	[GA]	94247-4	[PK]
22	Disc	(4)	94525	[T]	94525	[T]	94525	[T]
41	Spring Stop	(4)	93814-1	[P]	93814-2	[D1]	93814-3	[PK]
43	Screw (#10 - 32 x 1")	(4)	94436	[SS]	94436	[SS]	94436	[SS]
62	Nut (1/4" - 20)	(6)	93828	[SS]	93828	[SS]	93828	[SS]
63	Pipe Plug (1/4 - 18 N.P.T.)	(O)	93832-1	[P]	93832-2	[D2]	93832-3	[PK]
<input type="checkbox"/> 65	Fluid Cap	(O)	94245-1	[P]	94245-2	[GA]	94245-4	[PK]
<input type="checkbox"/> 66	Fluid Cap (with one blocked tube)	(O)	94344-1	[P]	94344-2	[GA]	94344-3	[PK]
<input type="checkbox"/> 68	Air Cap (with groove)	(1)	93804	[P]	93804	[P]	93804	[P]
<input type="checkbox"/> 69	Air Cap (with tongue)	(1)	93805	[P]	93805	[P]	93805	[P]
74	Pipe Plug (3/8 - 18 N.P.T.)	(O)	94478-1	[P]	94478-2	[D2]	94478-3	[PK]
131	Bolt (1/4" - 20 x 6-3/8")	(6)	94526	[SS]	94526	[SS]	94526	[SS]
205	Logo Plate	(2)	93919	[A]	93919	[A]	93919	[A]

AIR SECTION PARTS

Item	Description (size)	Qty	Part No.	Mtl	Item	Description (size)	Qty	Part No.	Mtl
102	"O" Ring (1/16" x 7/8" o.d.)	(3)	Y325-18	[B]	138	"O" Ring (0.103" x 0.818" o.d.)	(1)	94760	[U]
103	Bushing	(1)	93917	[D2]	144	"U" Cup (1/8" x 5/8" o.d.)	(2)	Y186-45	[B]
110	"U" Cup (1/8" x 13/16" o.d.)	(1)	Y186-54	[B]	<input type="checkbox"/> 145	Minor Valve Block	(1)	93807	[R]
<input type="checkbox"/> 111	Spool Assembly (includes items 110, 138 & 180)	(1)	67163	[D2]	146	"O" Ring (1/16" x 5/16" o.d.)	(2)	Y325-8	[B]
119	"O" Ring (0.106" x 0.587" o.d.)	(4)	15066	[B]	147	"O" Ring (1/16" x 7/16" o.d.)	(2)	Y325-11	[B]
132	Gasket	(1)	96153	[Kr]	161	"O" Ring (3/32" x 9/16" o.d.)	(2)	Y325-110	[B]
134	Screw (#4 - 20 x 0.295")	(3)	93942	[SS]	178	Trip Rod Assembly (includes item 119)	(2)	65145	[D2]
<input type="checkbox"/> 135	Valve Block	(1)	93806	[R]	179	Sleeve Assembly (includes item 119)	(1)	65144	[D2]
137	"O" Ring (1/16" x 1" o.d.)	(1)	Y325-20	[B]	180	"O" Ring (0.106" x 0.587" o.d.)	(1)	15066-U	[U]

MATERIAL CODE

[A] = Aluminum	[P] = Polypropylene (light gray)
[B] = Nitrile	High Density Polypropylene (green)
[C] = Carbon Steel	[R] = Ryton
[D1] = Acetal (orange)	[Sp] = Santoprene
[D2] = Acetal (white)	[SS] = Stainless Steel
[E] = E.P.R. / EPDM	[T] = PTFE
[GA] = Groundable Acetal (dark gray)	[U] = Polyurethane
[Kr] = Kraton	[Z] = Zinc
[PK] = Pure Kynar	

Quantities will vary, depending on the inlet / outlet option selected (refer to chart on page 5).

"Smart Parts", keep these items on hand in addition to the service kits for fast repair and reduction of down time.

PARTS LIST / PD02P-XXX-XXX

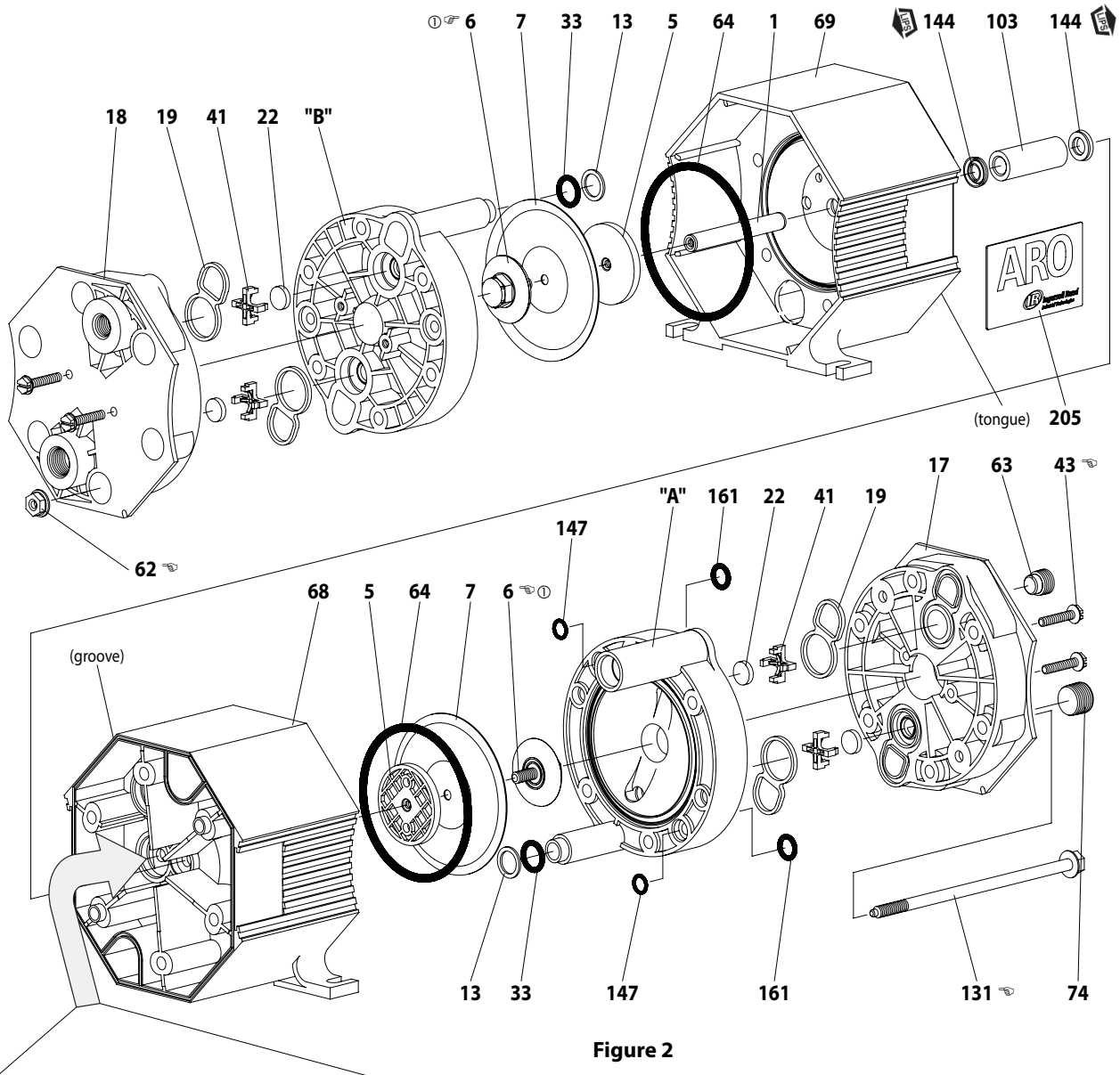

Figure 2

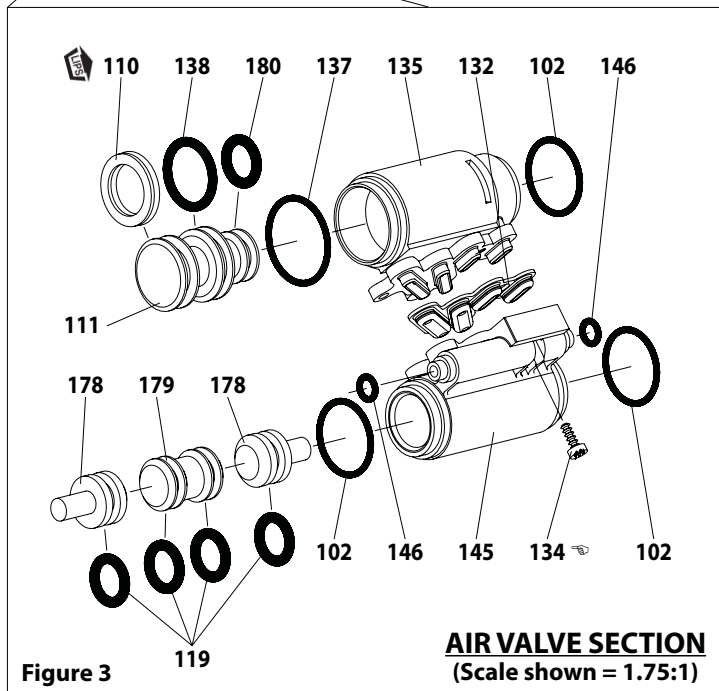

Figure 3

AIR VALVE SECTION
(Scale shown = 1.75:1)

Inlet / Outlet Options	Fluid Cap		Item 63	Item 74
	"A"	"B"	Qty	Qty
SI / SO	65	65	(1)	(1)
SI / DO	66	65	---	(1)
DI / SO	65	66	(1)	---
DI / DO	66	66	---	---

TORQUE REQUIREMENTS

NOTE: DO NOT OVERTIGHTEN FASTENERS.
 (6 / 5) Diaphragm screw / washer, 60 - 70 in. lbs (6.8 - 7.9 Nm).
 (43) Screw, 20 - 25 in. lbs (2.3 - 2.8 Nm).
 (62 / 131) Nut / bolt, 70 - 75 in. lbs (7.9 - 8.5 Nm). Tighten together alternately and evenly, then re-torque.
 (134) Screw, 3.5 - 4.5 in. lbs (0.40 - 0.51 Nm).

LUBRICATION / SEALANTS

Apply Lubriplate FML-2 grease (94276) to all "O" rings, "U" cups and mating parts.
 ① Apply Loctite® 242® to threads.

PUMP DISASSEMBLY AND REASSEMBLY

GENERAL PUMP REPAIR NOTES:

- Tools needed to complete disassembly and repair:
 - 5/16" wrench or socket, 7/16" socket, 5/8" wrench or socket, 3/8" Allen wrench, spanner wrench, torque wrench (measuring inch pounds), "O" ring pick.
- Once the pump is disassembled, you have the opportunity to clean and inspect all parts for wear. Look for deep scratches on metallic surfaces and nicks or cuts in "O" rings. Replace old parts with new ones as necessary.
- Take precautions to prevent cutting "O" rings upon installation.
- Lubricate "O" rings and "U" cups with Lubriplate. A packet of this lubricant is included in each Service Kit.
- Do not over-tighten fasteners. Refer to torque specification block on page 5.
- Re-torque fasteners following restart.

Service Kits available. From your local distributor.

(Kits also include Lubriplate grease packet.)

- SERVICE KIT: 637314-XX contains parts for a complete pump rebuild.
- SERVICE KIT: 637276 contains parts to rebuild the air valve.
- SERVICE KIT: 637313-XX contains parts to rebuild the diaphragms and checks.

FLUID SECTION DISASSEMBLY

1. Place the pump on a flat workbench.
2. Using 7/16" sockets, remove six (62) nuts and (131) bolts.
3. Set the pump on end, with the "air inlet" end up.
4. Using a flat blade screwdriver, remove (17) air inlet manifold and ("A") fluid cap.
5. Remove (13) back-up ring and (33) "O" ring from ("A") fluid cap.
6. Remove two (147) "O" rings from ("A") fluid cap.
7. Remove (18) manifold and ("B") fluid cap.
8. Remove (13) back-up ring and (33) "O" ring from ("B") fluid cap.
9. Using 5/8" wrenches on (6) diaphragm screws, unthread and remove diaphragm assemblies.
 - NOTE: Air valve section can be repaired at this time, refer to "Air Valve Disassembly".
10. Using a 5/16" wrench or flat blade screwdriver, remove two (43) screws from (17) air inlet manifold.
11. Separate (17) air inlet manifold and ("A") fluid cap. NOTE: (41) spring stops and (22) discs may fall out. If not, remove at this time.
12. Remove (19) seals and (161) "O" rings.
13. Disassembly of the opposite end of the pump is the same as the "air inlet" end, except for the following: a.) the opposite end does not contain (161) "O" rings and b.) the top tube has the outside shoulder, the bottom tube has the inside shoulder.
14. Wrap (1) rod in a shop rag and secure in a soft-faced vise.
15. Using a 5/8" wrench, unthread (6) diaphragm screw from (1) rod.
16. Using a 5/8" wrench on (6) diaphragm screw and a spanner wrench on (5) washer, unthread and remove (6) diaphragm screw.

FLUID SECTION REASSEMBLY

NOTE: Lubricate all "O" rings, "U" cups seals and their mating parts with 94276 Lubriplate upon assembly.

1. Place the new (7) diaphragms on the (6) diaphragm screw, with the bowed side of the diaphragm oriented against (6) diaphragm screw.
2. Assemble (5) washer to (6) diaphragm screw and torque to 60 - 70 in. lbs (6.8 - 7.9 Nm), using a spanner wrench and a 5/8" wrench. NOTE: Be sure not to strip the plastic nut.
3. Assemble (1) rod to one of the diaphragm assemblies and tighten finger tight.
4. Models PD02P-XXS-XTT only: Assemble (64) "O" rings into grooves in (68 and 69) air caps.
5. Assemble diaphragm assemblies into air caps and torque to 60 - 70 in. lbs (6.8 - 7.9 Nm), using 5/8" wrenches.
6. Assemble two (147) "O" rings to the raised air passages, opposite each other, inside (68) air cap.
7. Set ("A") fluid cap on the workbench, with the "tube side" down.
8. Assemble two (161) "O" rings to counterbores in ("A") fluid cap.
9. Assemble (22) disc and (41) spring stop to the check seat nearest the top tube of ("A") fluid cap (top tube has the shoulder on the outside).
10. Assemble (41) spring stop and (22) disc (disc on top) to check seat nearest the bottom tube (shoulder on outside).
11. Lubricate seal grooves in (17) air inlet manifold and assemble (19) seals to grooves.
12. Assemble (17) air inlet manifold to ("A") fluid cap, aligning fluid inlet with lower tube (shoulder on outside).
13. Secure with two (43) screws. Torque to 20 - 25 in. lbs (2.3 - 2.8 Nm), using a 5/16" wrench.
14. Repeat steps 9 thru 13 for opposite end of pump. NOTE: The tubes are reversed on ("B") fluid cap (top tube has outside shoulder).
15. Assemble (33) "O" rings and (13) back-up rings to the outside shoulder of tubes of ("A" and "B") fluid caps.
16. Assemble (17) air inlet manifold and components into (68) air cap, being sure to align groove in manifold with rib in air cap.
17. Assemble (18) manifold and components into (69) air cap, being sure to align groove in manifold with rib in air cap.
18. Assemble six (131) bolts and (62) nuts to pump and torque to 70 - 75 in. lbs (7.9 - 8.5 Nm), using 7/16" sockets, hold the nut, torque the bolt only. NOTE: Allow the pump to sit for at least 15 minutes, then re-torque bolts to 70 - 75 in. lbs (7.9 - 8.5 Nm).

AIR VALVE SECTION DISASSEMBLY

1. Refer to "Fluid Section Disassembly", steps 1 thru 9.
2. Separate (68 and 69) air caps, releasing (103) bushing and logo plates.
3. Remove air valve assembly, (102, 137 and 146) "O" rings and (144) "U" cups from air caps.
4. Remove (111) spool assembly, (178) trip rods and (179) sleeve assembly from (145) valve block.
5. Remove "O" rings and "U" cup from (111) spool assembly.
6. Inspect (119) "O" rings on (178) trip rods and (179) sleeve assembly.
7. Remove three (134) screws, releasing (145) minor valve block and (132) gasket.

AIR VALVE SECTION REASSEMBLY

1. Assemble (132) gasket and (145) minor valve block to (135) valve block, securing with three (134) screws. NOTE: Torque to 3.5 - 4.5 in. lbs (0.40 - 0.51 Nm).
2. Assemble (119) "O" rings to (178) trip rods and (179) sleeve assembly.
3. Assemble (178) trip rods and (179) sleeve assembly into (145) valve block.
4. Assemble (138 and 180) "O" rings and (110) "U" cup to (111) spool assembly.
5. Assemble (111) spool assembly into (135) valve block, with small end of spool going into valve block first.
6. Assemble (102, 137 and 146) "O" rings to valve block.
7. Assemble (144) "U" cups to (68 and 69) air caps.
8. Place one (68 or 69) air cap on end, with legs down and seat valve block into air cap.
9. Assemble logo plates and (103) bushing into air cap.
10. Assemble other air cap to air cap, aligning logo plates, (178) trip rod and (103) bushing.
11. Refer to "Fluid Section Reassembly", steps 5 thru 18 to complete reassembly.

TROUBLE SHOOTING

Air Motor stalls.

- Check for blown diaphragm
- Check for damaged "O" rings on the spool.
- Check for damaged "O" rings on the trip rod.
- Check valve block gasket for leakage.

Air leaks from exhaust.

- Check for damaged "O" rings on the valve block, spool or trip rod.
- Check gasket between valve blocks for leakage.

- "U" cups on connecting rod bushing are damaged or installed backwards.

Fluid leaks from exhaust.

- Check for diaphragm damage.
- Check for diaphragm screws not adequately torqued.

Low flow or pump continues to cycle after shut-off.

- Check for trapped air if the pump is oriented where the inlet check is above the outlet check. Temporarily increase the flow or re-prime the pump.
- Check for damaged seats or foreign matter clogging the check assembly.

Air leaks from pump (other than exhaust).

- Check for bolts not evenly or adequately torqued.
- Check for "O" ring missing / damage between the fluid cap and the air cap on the air inlet side.

External fluid leaks from pump.

- Check for bolts not properly torqued.
- Check for damaged "O" rings on the fluid cap tubes.
- Check for damaged "O" rings on the valve check.
- Check for damaged diaphragm seal.

Pump operates but dispenses little or no fluid.

- Check for obstruction in fluid line.
- Check for foreign matter clogging check assemblies. Note: Install a fluid screen on the material inlet hose if the problem continues.
- Suction line too small.
- Check for air leakage at the air / fluid inlet pipe plugs. Use PTFE tape or pipe sealant upon assembly.

TYPICAL CROSS SECTION

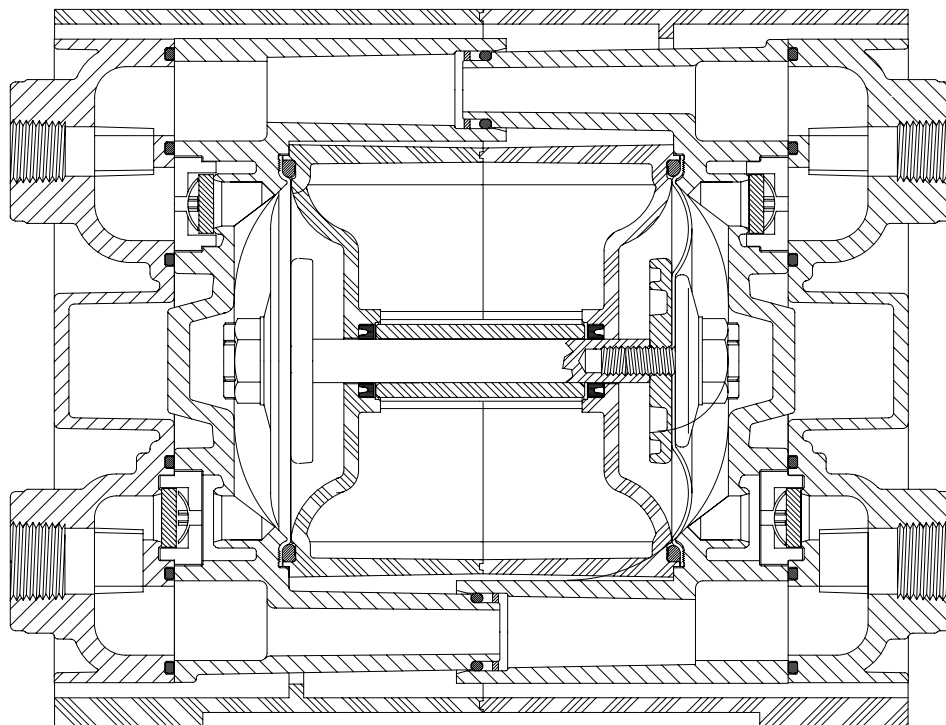
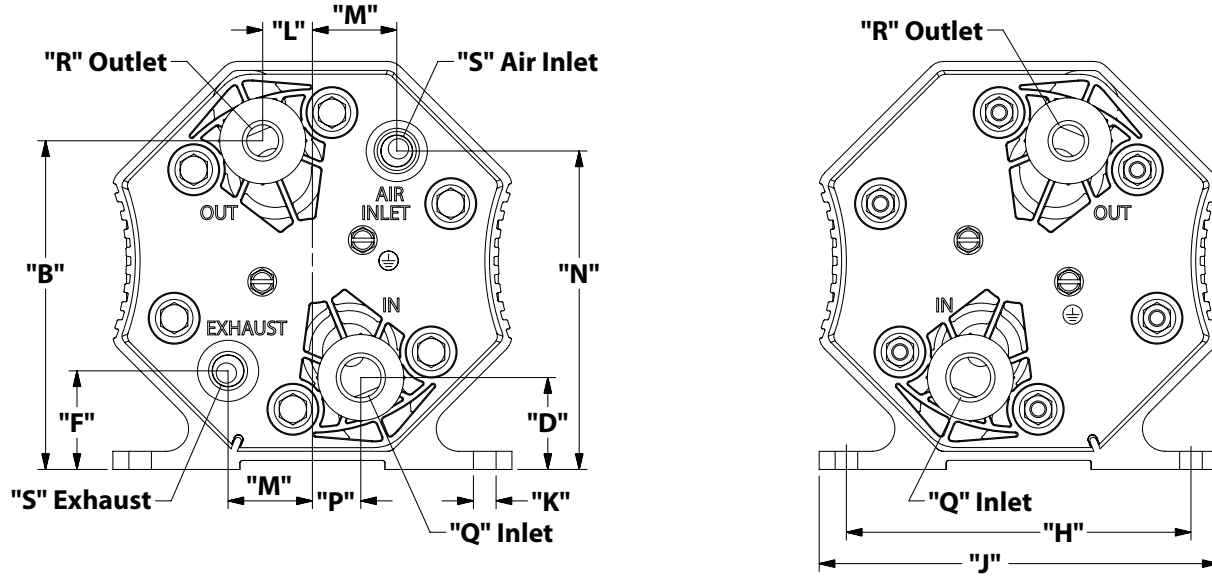

Figure 4

DIMENSIONAL DATA

Dimensions shown are for reference only, they are displayed in inches and millimeters (mm).

END VIEWS



SIDE VIEW

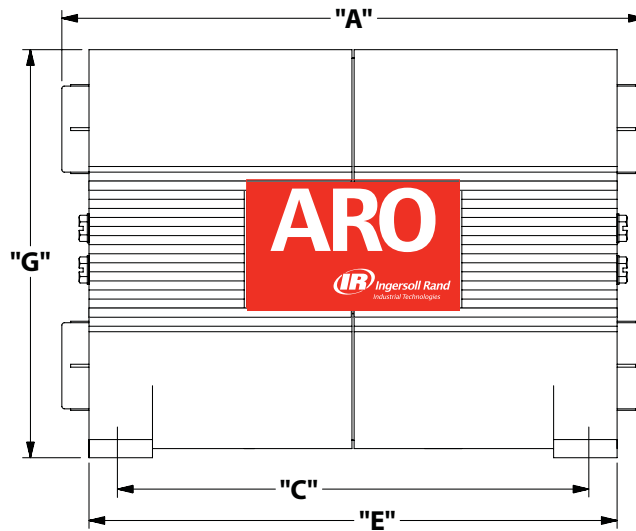

DIMENSIONS

A - 8-1/32" (204.0 mm)	G - 5-5/8" (142.9 mm)	N - 4-25/64" (111.5 mm)
B - 4-17/32" (114.9 mm)	H - 4-3/4" (120.7 mm)	P - 21/32" (16.6 mm)
C - 6-1/2" (165.1 mm)	J - 5-1/2" (139.7 mm)	Q - 3/8 - 18 N.P.T.F. - 1
D - 1-5/16" (33.0 mm)	K - 5/16" (7.9 mm)	R - 1/4 - 18 N.P.T.F. - 1
E - 7-9/32" (184.9 mm)	L - 11/16" (17.3 mm)	S - 1/4 - 18 P.T.F.
F - 1-23/64" (34.5 mm)	M - 1-11/64" (29.5 mm)	

Figure 5